

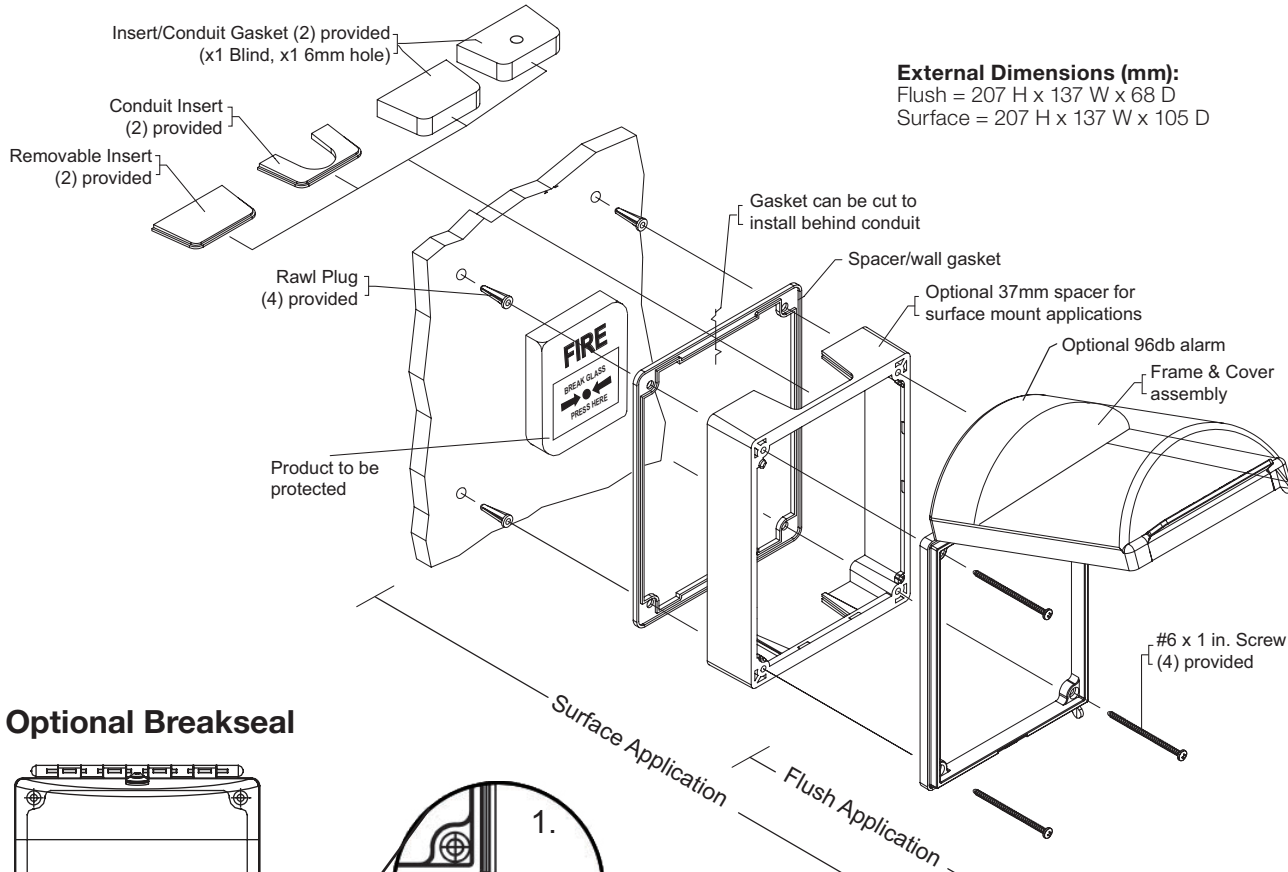

Safety Technology International

European Office
Taylor House • 34 Sherwood Road • Bromsgrove
Worcestershire • B60 3DR • England
Tel: 44 (0) 1527 520 999 Fax: 44 (0) 1527 501 999
E-mail: info@sti-emea.com • Web: www.sti-emea.com

USA - Headquarters
2306 Airport Road • Waterford, Michigan 48327-1209
Phone: 248-673-9898 • Fax: 248-673-1246
Toll Free: 800-888-4784 • E-mail: info@sti-usa.com
Web: www.sti-usa.com



External Dimensions (mm):
Flush = 207 H x 137 W x 68 D
Surface = 207 H x 137 W x 105 D

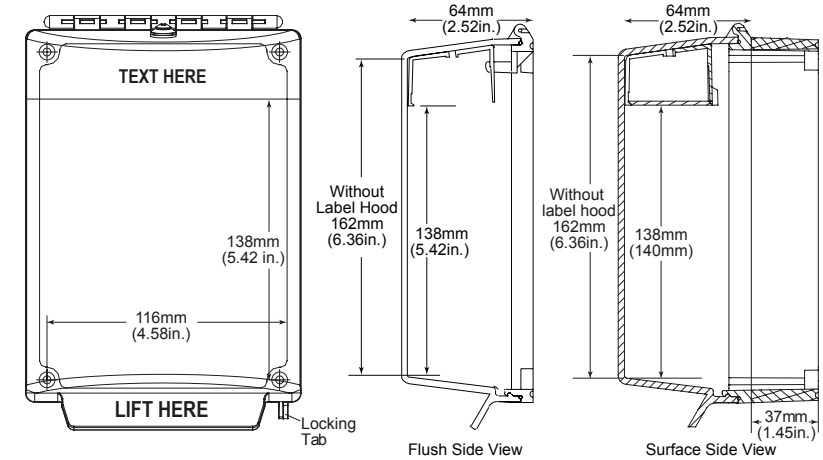

PRODUCT DIMENSIONS

INSTALLATION NOTES

Before drilling mounting holes place spacer, frame and cover over your device. Position it so device functions properly and cover closes with no interference.

1. Mark the position for the 4 fixing screws. Drill the holes using a 6mm masonry drill bit and fit the Universal Stopper with wall fixings provided.
2. If using a Surface mounted spacer, please note that it provides cable entry facilities, for conduit, cable and trunking. A 37mm depth spacer is supplied as standard.
3. Where the weather gasket is required, position this between the spacer (surface) and the wall.
4. Ensure the servicing pin is removed from the alarm unit on those fitted with an integral sounder. The pin should be retained in the event any maintenance is carried out.

Three year warranty or a one year limited warranty (from date of purchase) on most products. See website for details. Electronic warranty form at www.sti-usa.com/wc14.

Optional Breakseal

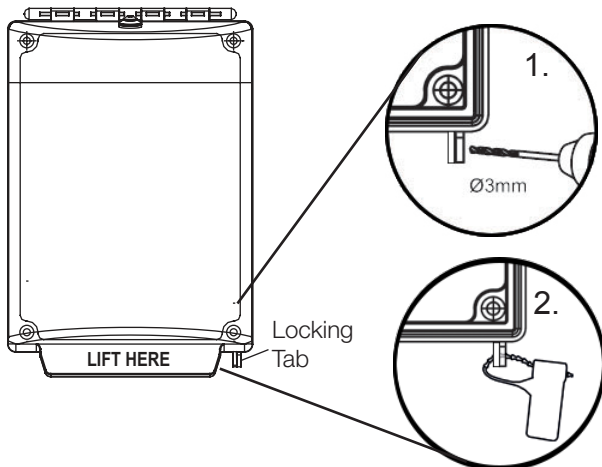

Replacing the battery (STI-13000 Series with Sounder)

To replace the 9V PP3 battery in the alarm unit, insert the servicing pin, remove the two screws on the underside of the alarm unit and replace battery. Reassemble ensuring to remove the servicing pin. The pin should always be retained.

Installation Tools Required:

1. 6mm Masonry Drill Bit
2. Philips Head Screw Driver

Universal Stopper Accessories

STI-1331	37mm Spacer
CKS001	Sounder Conversion Kit
E009	Servicing Pin
STI/BS	Breakseals (Quantity. 10)

INSTALLATION OF UNIVERSAL STOPPER® STI-13000 Series

All specifications and information shown were current as of publication and are subject to change without notice.