

# **OS2 Hardware User Manual**

*For Rev7 Sensors*

**Ouster**

**Jul 05, 2023**

# Contents

---

<b>1</b>	<b>Important Safety Information</b>	<b>4</b>
1.1	Safety & Legal Notices . . . . .	4
1.2	Proper Assembly, Maintenance and Safe Use . . . . .	7
1.2.1	Assemblage correct et utilisation sûre . . . . .	8
1.3	Sensor Cleaning . . . . .	9
1.4	Regulatory compliance . . . . .	10
1.4.1	For USA . . . . .	10
1.4.2	For EU . . . . .	10
1.4.3	EMC . . . . .	10
<b>2</b>	<b>Sensor</b>	<b>11</b>
2.1	Overview . . . . .	11
2.2	OS2 Product Models . . . . .	11
<b>3</b>	<b>Mechanical Interface</b>	<b>11</b>
3.1	Included Components . . . . .	11
3.2	Mechanical Drawings . . . . .	12
3.3	Mounting Guidelines . . . . .	14
3.4	Sensor Grounding Simplified . . . . .	16
3.5	Operating Temperatures . . . . .	16
<b>4</b>	<b>Electrical Interface</b>	<b>16</b>
4.1	Power Supply and Operating Voltage . . . . .	16
4.2	Connection through the Interface Box . . . . .	17
4.3	Direct Cable Connection and Pinout . . . . .	17
4.3.1	Cable Pinout Diagram for Type 1, 2 and 3 (1000BASE-T) . . . . .	17
4.3.2	Cable Pinout Diagram for Type 4 (1000BASE-T1) . . . . .	19
<b>5</b>	<b>Digital IO</b>	<b>20</b>
5.1	SYNC_PULSE_IN . . . . .	20
5.2	MULTIPURPOSE_IO (MIO) . . . . .	21
<b>6</b>	<b>OS2 CAD files</b>	<b>22</b>
<b>7</b>	<b>Accessories</b>	<b>22</b>
7.1	Cables . . . . .	22
7.1.1	Cable Characteristics . . . . .	23
7.1.2	Electrical Characteristics (POWER and GROUND wires) . . . . .	23
7.2	Interface Box . . . . .	24
7.2.1	Interface Box ( <b>Important Notice</b> ) . . . . .	25
7.2.2	Types and Physical Characteristics . . . . .	26
7.2.3	High Current Interface Box (PCBA 830-104249) - Standard . . . . .	27
7.2.3.1	Cable Connection and Pinout . . . . .	28
7.2.3.2	Specification . . . . .	28
7.2.4	High Current Modular Interface Box (PCBA PN- 830-103125) . . . . .	29
7.2.4.1	Specification . . . . .	30
7.2.5	Interface Box 24V (Legacy Type 1 and Type 2) . . . . .	30
7.2.6	Connectors . . . . .	31
7.3	Mounting Interface Box . . . . .	32

7.3.1	High Current Modular Interface Box (PCBA PN- 830-103125) . . . . .	32
7.3.2	High Current (12 or 24V) Interface Box (PCBA 830-104249) - Standard . . . . .	32
7.3.3	Electrical Characteristics . . . . .	33
7.3.4	Over-current Protection . . . . .	33
7.4	Power Supply . . . . .	33
7.4.1	Selecting a Power Supply Cord/Cord-set . . . . .	34
7.4.2	Environmental Ratings . . . . .	34
<b>8</b>	<b>GPS/GNSS Synchronization Guide</b>	<b>34</b>
8.1	Setting up your GPS/GNSS . . . . .	34
8.2	Connecting the Hardware . . . . .	35
8.2.1	Connection using the GPS Port . . . . .	35
8.2.2	Connection using the Pin out . . . . .	36
8.3	Configuring the Ouster Sensor . . . . .	37
<b>9</b>	<b>Support</b>	<b>37</b>

---

# 1 Important Safety Information

---

## 1.1 Safety & Legal Notices

---

The OS2-128, OS2-64, and OS2-32 have been evaluated to be **Class 1 laser products** per **60825-1: 2014 (Ed. 3)** and operate in the 865nm band.

L'OS2-128, l'OS2-64, et l'OS2-32 répondent aux critères des **produits laser de classe 1**, selon la norme **IEC 60825-1: 2014 (3ème édition)** et émettent dans le domaine de l'infrarouge, à une longueur d'onde de 865nm environ.

**FDA 21CFR1040 Notice:** OS2-128, OS2-64, and OS2-32 comply with FDA performance standards for laser products except for deviations pursuant to Laser Notice No. 56, dated January 19, 2018.

**Notice FDA 21CFR1040:** L'OS2-128, l'OS2-64, et l'OS2-32 sont conformes aux exigences de performances établies par la FDA pour les produits laser, à l'exception des écarts en application de l'avis n°56, daté du 19 janvier 2018.

The following symbols appear on the product label and in the user manual have the following meaning.



Figure 1.1: Class 1 Laser Product



Figure 1.2: Caution "Sharp Edges"



Figure 1.3: This symbol indicates that the sensor emits laser radiation.



Figure 1.4: This symbol indicates the presence of a hot surface that may cause skin burn.

### CAUTIONS:

- The OS2 is a hermetically sealed unit, and is non user-serviceable.
- Use of controls, or adjustments, or performance of procedures other than those specified herein, may result in hazardous radiation exposure.
- Use of the OS2 is subject to the Terms of Sale that you agreed and signed with Ouster or your distributor/integrator. Included in these terms are the prohibitions of:
  - Removing or otherwise opening the sensor housing
  - Inspecting the internals of the sensor
  - Reverse-engineering any part of the sensor
  - Permitting any third party to do any of the foregoing
- Operating the sensor without the attached mount that is shipped with the sensor, or attaching the sensor to a surface of inappropriate thermal capacity runs the risk of having the sensor overheat under certain circumstances.
- This lidar sensor features a modular cap design to enable more flexible mounting and integration solutions for the sensor.
- The modular cap design increases design flexibility but it does not remove the need for thermal management on top of the sensor. The attached radial cap serves an important thermal management purpose and the sensor will not operate properly without a cap.
- Operation for extended periods of time without the cap will result in system errors and the sensor overheating. The cap can be replaced with alternative solutions but it cannot be left off altogether.
- If you wish to operate the sensor with a custom mounting solution, please contact our [Field Application Team](#) and we can answer your questions and provide guidance for achieving proper operations.

- This product emits Class 1 invisible laser radiation. The entire window is considered to be the laser aperture. While Class 1 lasers are considered to be "eye safe", avoid prolonged direct viewing of the laser and do not use optical instruments to view the laser.
- When operated in an ambient temperature > 40 °C, the metallic surfaces of the sensor may be hot enough to potentially cause skin burn. Avoid skin contact with the sensor's base, lid and the heatsink when the sensor is operated under these conditions. The sensor should not be used in an ambient temperature above 60°C. The maximum safety certified ambient operating temperature is 60°C.

## **PRECAUTIONS:**

- L'OS2 est une unité hermétiquement scellée, qui ne peut être entretenue ou modifiée par l'utilisateur.
- L'utilisation de commandes, de réglages, ou l'exécution de procédures autres que celles spécifiées dans le présent document peuvent entraîner des rayonnements laser dangereux.
- L'utilisation de l'OS2 est soumise aux conditions de vente signées avec Ouster ou le distributeur/intégrateur, incluant l'interdiction de:
  - Retirer ou ouvrir de quelque façon le boîtier du capteur
  - Analyser les composants internes du capteur
  - Pratiquer la rétro-ingénierie de toute ou partie du capteur
  - Autoriser une tierce personne à mener les actions listées ci-dessus
- L'utilisation du capteur sans le support (fourni avec le capteur) ou sans contact avec une surface ayant des capacités thermiques adéquates peut entraîner une surchauffe du capteur dans certaines conditions.
- Ce capteur présente une conception avec un dissipateur thermique supérieur modulaire, ceci pour apporter plus de flexibilité de montage et d'intégration au capteur.
- Cette conception modulaire augmente la flexibilité de conception mais ne supprime pas le besoin de dissipation thermique au-dessus du capteur. Le dissipateur thermique radial fourni est essentiel à une bonne gestion thermique. Le capteur ne fonctionnera pas correctement sans cette pièce.
- Une utilisation prolongée du capteur sans le dissipateur thermique supérieur peut résulter à des erreurs système ainsi qu'à une surchauffe du capteur pouvant aller jusqu'à son extinction. Le dissipateur thermique fourni peut être remplacé par une autre solution de dissipation thermique adéquate, mais ne doit pas être simplement retiré.
- Si vous souhaitez utiliser votre capteur avec une dissipation thermique personnalisée, merci de contacter notre [Équipe Support](#) qui pourra répondre à vos questions et vous apporter le support et le conseil nécessaire.
- Ce produit émet un rayonnement laser invisible de classe 1. L'ouverture de sortie du laser est constituée par la fenêtre du capteur dans sa totalité. Même si les lasers de classe 1 ne sont pas considérés comme dangereux pour les yeux, ne regardez pas directement le rayonnement laser de façon prolongée et n'utilisez pas d'instruments optiques pour observer le rayonnement laser.

- Lors d'une utilisation à température ambiante supérieure à 40°C, la surface métallique du capteur peut présenter des risques de brûlures pour la peau. Dans ces conditions, il est important d'éviter tout contact avec la partie supérieure, la base ou le dissipateur thermique du capteur. Le capteur ne doit pas être utilisé à une température ambiante supérieure à 60°C. 60°C est la température maximale certifiée d'opération sûre du capteur.

**Equipment Label:** Includes model and serial number and a notice that states the unit is a Class 1 Laser Product, is affixed on the base extension. It is only visible after the attached mount with which the Sensor is shipped, is removed. For location details please refer to figure [Sensor Components \(Mechanical Drawings\)](#) in the Mechanical Interface Section.

**L'étiquette de l'équipement**, comprenant le modèle, le numéro de série, et la classification du produit laser (ici, classe 1), est apposée au-dessous de la base du boîtier du capteur. Il n'est visible qu'après avoir retiré le diffuseur de chaleur avec lequel le capteur est expédié. L'emplacement est décrit avec précision dans la section [Sensor Components \(Mechanical Drawings\)](#).

Electromagnetic Compatibility: The OS2 is an FCC 47 CFR 15 Subpart B device. This device complies with part 15 of the FCC Rules. Operation is subject to the following conditions: (1) This device may not cause harmful interference, and (2) this device must accept any interference received, including interference that may cause undesired operation.

"Ouster" and "OS2" are both registered trademarks of Ouster, Inc. They may not be used without express permission from Ouster, Inc.

If you have any questions about the above points, contact us at [Ouster Legal](#).

## 1.2 Proper Assembly, Maintenance and Safe Use

---

The OS2 can be easily set up by following the instructions outlined in [Mounting Guidelines](#). Any mounting orientation is acceptable. Each sensor is shipped with an attached mount that can be used for test or normal use within the specified operating conditions. The sensor may also be affixed to any other user specific mount of appropriate thermal capacity. Please contact Ouster for assistance with approving the use of user specific mounting arrangements.

Any attempt to utilize the sensor outside the environmental parameters delineated in the OS2 datasheet may result in voiding of the warranty.

When power is applied, the sensor powers up and commences boot-up with the laser disabled. The boot-up sequence is approximately 60s in duration, after which the internal sensor optics subassembly commences spinning, the laser is activated, and the unit operates in the default 1024 x 10 Hz mode. When the sensor is running, and the laser is operating, a faint red flickering light may be seen behind the optical window.

Note that the OS2 utilizes an 865nm infrared laser that is only dimly discernible to the naked eye. The sensor is fully Class 1 eye safe, though Ouster strongly recommends against peering into the optical window at close range while the sensor is operating. Ouster sensors are equipped with a multi-layer series of internal safety interlocks to ensure compliance to Class 1 Laser Eye Safe limits.

The OS2 is a hermetically sealed unit, and is not user-serviceable. Any attempt to unseal the enclosure has the potential to expose the operator to hazardous laser radiation.

The sensor user interface may be used to configure the sensor to a number of combinations of scan rates and resolutions other than the default values of 1024 x 10 Hz resolution. In all available combinations, the unit has been evaluated by an NRTL to remain within the classification of a Class 1 Laser Device as per IEC 60825-1:2014 (Ed. 3).

### **1.2.1 Assemblage correct et utilisation sûre**

L'OS2 s'installe facilement en fixant la base sur un support percé de trous concordants, et en suivant les instructions d'interconnexion décrites dans la section [Mounting Guidelines](#). Toute orientation de montage est acceptable. Chaque capteur est expédié équipé d'un dissipateur de chaleur, utilisable en phase de test et en conditions normales. Néanmoins tout autre support présentant une capacité thermique appropriée pour l'application de l'utilisateur peut être utilisé. Veuillez contacter Ouster dans le cas où un montage spécifique à votre application serait nécessaire.

Toute tentative d'utilisation du capteur en dehors des paramètres environnementaux définis dans la fiche technique de l'OS2 peut entraîner l'annulation de la garantie.

Lorsque le capteur est sous tension, celui-ci démarre et commence son initialisation avec le laser désactivé. Le temps de démarrage est d'environ 60s, après quoi le sous-système optique entre en rotation et le laser est activé, le capteur opère alors dans son mode par défaut de 1024 x 10 Hz. Lorsque le capteur est en marche et que le laser est activé, on peut apercevoir une faible lumière rouge vacillante derrière la vitre teintée. L'OS2 utilise une longueur d'ondes infra-rouge de 865nm nm à peine perceptible pour l'œil humain, et le rayonnement laser IR émis est sans danger pour les yeux. Cependant, bien que les rayonnements laser de classe 1 soient sans danger dans des conditions raisonnablement prévisibles, Ouster recommande fortement de ne pas regarder fixement la vitre teintée pendant que le capteur est en marche. L'OS2 est une unité hermétiquement scellée, qui ne peut pas être entretenue, modifiée ou réparée par l'utilisateur. Toute tentative d'ouverture du boîtier a pour risque d'exposer l'opérateur à un rayonnement laser dangereux.

L'OS2 est une unité hermétiquement scellée, qui ne peut pas être entretenue, modifiée ou réparée. Toute tentative d'ouverture du boîtier a pour risque d'exposer l'opérateur à un rayonnement laser dangereux.

Les capteurs Ouster sont équipés d'une série de dispositifs de sécurité à plusieurs niveaux, de façon à assurer en toutes circonstances le respect des limites d'irradiance correspondant aux rayonnements lasers de classe 1, sans danger pour les yeux.

L'interface utilisateur du logiciel du capteur peut être utilisée pour configurer le capteur selon un certain nombre de combinaisons de vitesses de balayage et de résolutions autres que les valeurs utilisées par défaut, respectivement de 1024 x 10 Hz.

## 1.3 Sensor Cleaning

---

All Ouster Sensor windows are made from polycarbonate. Based on the sensor usage you may see dust, bugs and/or layers of mud/debris on the window. Before you attempt to clean your sensor, please read the instructions below on best practices for cleaning Ouster Sensors.

### **Required Materials:**

- Few clean microfiber cloths
- Warm water
- Mild liquid dishwashing soap
- Spray bottle with clean water
- Spray bottle with mild soapy water
- 99% Isopropyl alcohol

### **Warning:**

- Avoid getting water into the power connector.
- Avoid using hard water when cleaning the sensor.
- Do not use acetone to clean the window. It will embrittle the polycarbonate.
- Do not wipe dirt directly from the sensor. Spray it off with warm water first.

### **Procedure:**

- Using the 99% isopropyl alcohol and a clean microfiber towel, wipe away bugs/mud/debris from the sensor.
- Spray the sensor with warm, mild-soapy water and gently wipe the sensor with a clean microfiber towel. Wipe along the curve of the sensor, not top-to-bottom (think moving with the grain).
- Spray the sensor with clean water to rinse off the soap and dry with a second microfiber towel.
- Enjoy your clean window.

## 1.4 Regulatory compliance

---

### 1.4.1 For USA

#### Laser Safety:

- IEC/EN 60825-1:2014 Class 1 eye safe
- FDA US 21CFR1040 Notice 56 Class 1

#### Product Safety:

- UL 62368-1
- CSA 22.2 No. 62368-1-19

#### EMC:

- FCC 47CFR Part 15, Subpart B, Class A

### 1.4.2 For EU

#### Laser Safety:

- IEC/EN 60825-1:2014 Class 1 eye safe

#### Product Safety:

- EN/IEC 62368-1

### 1.4.3 EMC

- EN 55032:2012/AC 2013; CISPR 32:2015
- EN 55024:2010; CISPR 24:2010
- EN 61000-3-2:2014
- EN 61000-3-3:2013



Figure 1.5: CE, RoHS & UKCA compliant

---

**Note:** (For UKCA Compliance)

Ouster UK (Ltd): 125 Princes Street, Edinburgh EH2 4AD, Scotland, United Kingdom.

Contact Person: Neil Calder, Phone Number: +44(0).131.563.9078

---

## 2 Sensor

---

### 2.1 Overview

---

The OS2 offers an industry-leading combination of price, performance, reliability, size, and weight. It is designed for indoor/outdoor all-weather environments and a long lifetime.

The OS2 family of sensors consist of three models, the OS2-128, OS2-64, and OS2-32, with differing vertical resolution, but identical mechanical dimensions.

For the purposes of this document, the term "OS2" refers to the family of sensors, and only where there is a difference in performance will each model be referred to by its specific model designation.

The contents of this manual are applicable only to Rev7 sensors. Please find the sticker on the top cap or the bottom of the sensor that will have all the information regarding **product type**, **serial number** and **part number**. For all other sensor hardware revisions, please refer to their respective [hardware user manual](#).

### 2.2 OS2 Product Models

---

The OS2 is available with 128, 64, or 32 beams of vertical resolution and with Uniform, Gradient, Above Horizon, or Below Horizon beam spacing options. Product specs and more information on these configurations can be found on the [OS2 product page](#).

## 3 Mechanical Interface

---

### 3.1 Included Components

---

The OS2 is shipped with the following items:

- Sensor
- Interface box cable/connector
- 24V AC/DC power supply (2 meters)
- RJ45 cable (1 meter)

### 3.2 Mechanical Drawings

Table 3.1: Sensor Components (Mechanical Drawings)

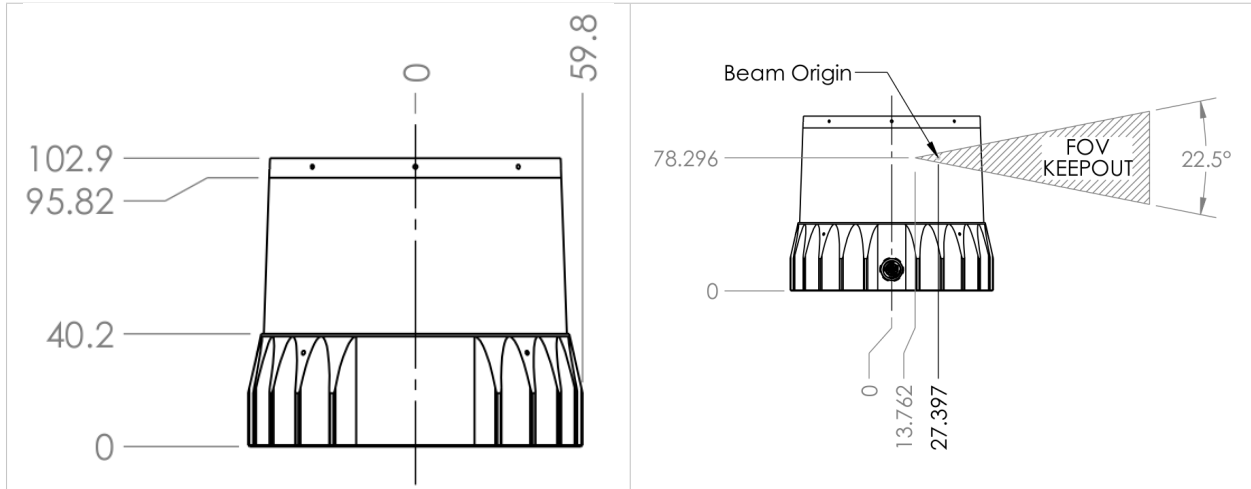
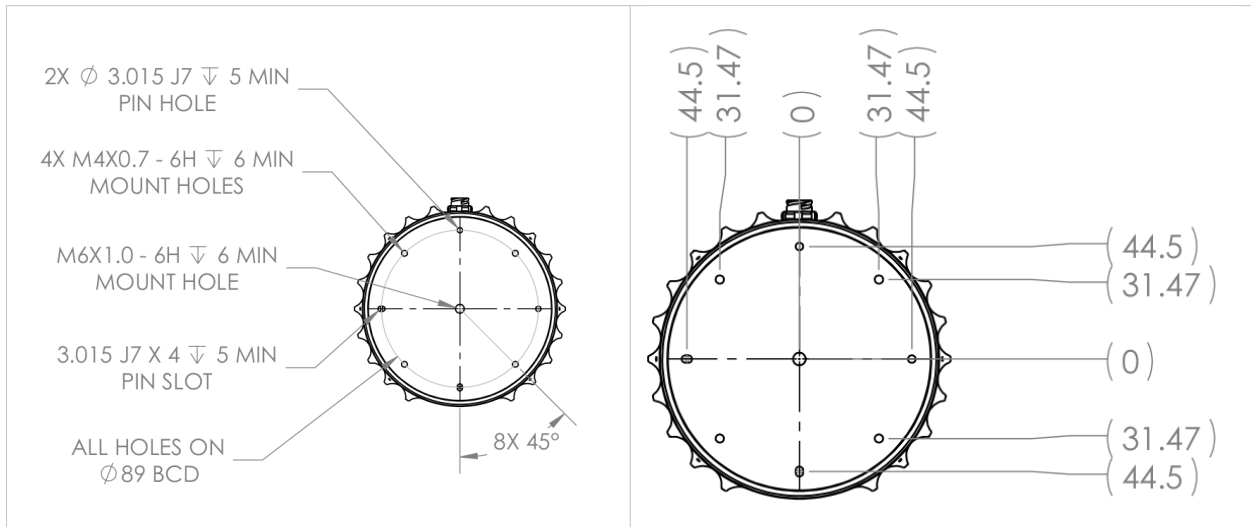

Table 3.2: Mechanical Drawings (cntd.)



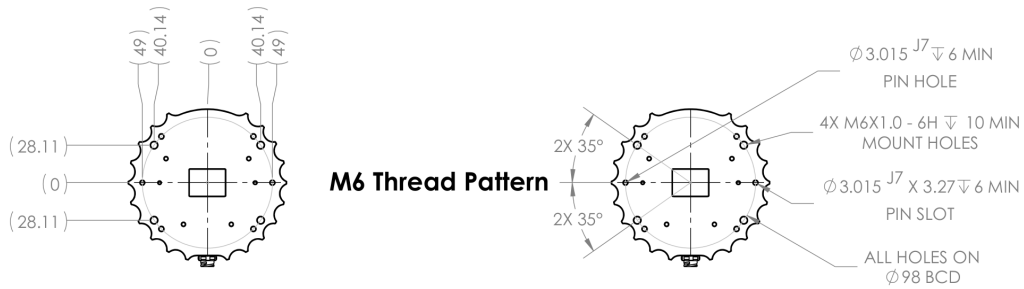

Figure 3.1: M6 Thread Pattern

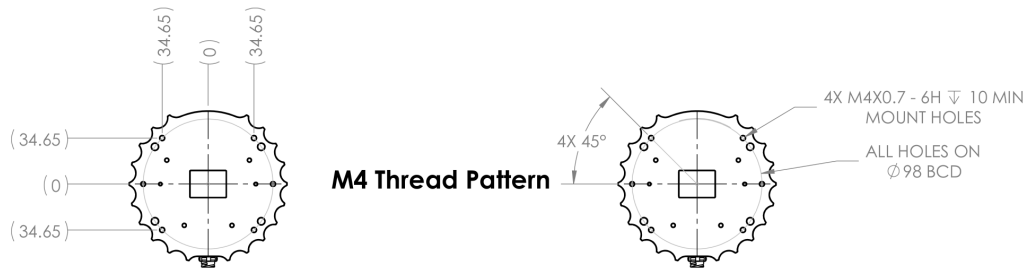

Figure 3.2: M4 Thread Pattern

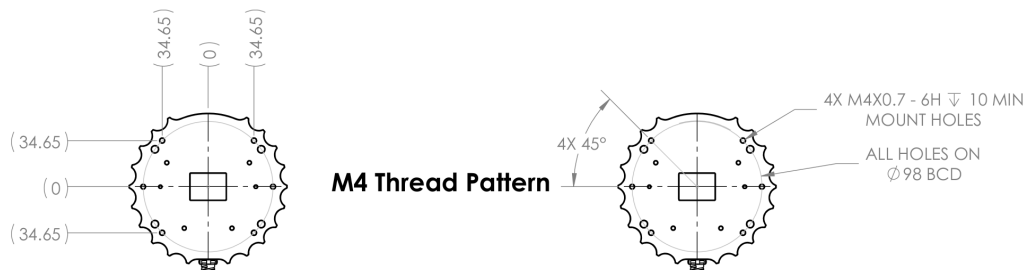

Figure 3.3: M3 Thread Pattern

Downloadable CAD files for the OS2 can be found online at [Ouster Download Page](#)

**Warning:** The water ingress protection rating for the sensor is only valid if the I/O cable is plugged into the panel mount connector on the base of the sensor, and the locking collet rotated to the properly locked condition. The cable and plug are an element of the sensor ingress protection system. Without the connected cable the ingress protection rating may be compromised. Bending the cable at a sharp angle directly after egress from the plug over mold should also be avoided. Sharp bends and high axial stresses on the cable immediately adjacent to the plug over mold may create a moisture ingress path into the connector. Please refer to [Cable Characteristics](#) for more information on minimum bend radius requirements.

### 3.3 Mounting Guidelines

---

Our sensors ship with modular mounting options. The sensor can be mounted in any orientation. Proper mounting will ensure optimal sensor performance and efficient heat dissipation.

- Mount to a material with high thermal conductivity. The following are recommended aluminum alloys and their thermal conductivities:
  - 1) 6061: 167 W/m-K
  - 2) 7075: 130 W/m-K
  - 3) 2024: 121 W/m-K
- Ensure interfaces are clean and free from debris.
- M3 screws are for mounting the sensor directly to the surface. M8 screws are used for mounting the base plate to the surface. The screw hole pattern is presented in the Sensor drawing above [Sensor Components \(Mechanical Drawings\)](#).
- Torque bolts appropriately for the mount material and bolts. A torque of 146cNm is recommended for a2 stainless steel screws.
- Use TIM (Thermal Interface Material) for any irregular or unmachined surfaces.
- Do not overconstrain the sensor if mounting to both the top and the bottom.

---

**Note:** Do not mount the device solely from the top. The primary mounting attachment site is at the bottom of the device as it ensures adequate mechanical support and ruggedness.

---

- Use a thermally conductive pad to ensure good conductivity while not over constraining.
- Ensure your implementation maintains the base and top of the sensor at no greater than 25°C above ambient with an ambient less than 50°C.
- The shape of any heatsink should maximize the surface area for free and forced convection while being thick enough to allow the heat to conduct through the material.

#### **Mounting on a drywall:**

- When mounting a sensor (needs to be mounted on a baseplate) on a drywall or a false ceiling, Ouster recommends the mounting means must be able to support 3X the weight of the sensor.
- Check the wall condition and make sure its not aging. If your drywall is ageing or deteriorating, it's likely to bow and bend with the added weight of the sensor, baseplate and cables connected to it. This could cause a potentially dangerous situation where the wall anchors could pull out and leave the sensor hanging or drop down.
- CAD Files and mechanical drawings are provided by Ouster to verify proper sensor and base plate dimensions that can help measuring the surface for proper placement and mounting.
- Check for studs using a stud finder. As these studs are hidden behind drywall, you'll need to

locate them (if available) with a stud finder. Lay the stud finder flat on the wall where you want to position your sensor and turn it on. Slowly move it across the wall from left to right until it beeps or lights up. Note the location with a pencil mark and continue along the wall until you find the next stud. Continue this process until you've found all the studs where you plan to install the sensor.

- Drill pilot holes and mount the sensor carefully. Make sure you check for proper installation and that all screws are tightly fit.

#### **Mounting on a concrete wall:**

- Check the wall conditions before drilling any pilot holes and make sure there are no cracks or molds or hollow bricks.
- Using the CAD Files and mechanical drawings provided by Ouster, mark a template with a pencil on the wall where you want to mount the sensor (needs to be mounted on a baseplate).
- Using appropriate drill bit, drill pilot holes accordingly and mount the sensor carefully.
- For concrete walls, make sure to choose an appropriate stainless steel screw or a wedge anchor based on the type of wall.
- Make sure you check for proper installation of the sensor and that all screws are tightly fit.

---

**Note:** If you do not feel comfortable following the steps above for mounting please contact [Ouster Support](#) so we can walk you through the steps thoroughly.

---

**Warning:** The sensor cables are not rated for running in any environmental air handling space, including source ducts or air returns that are commonly the spaces above false ceilings and are not in compliance with NFPA 70 (US NEC), 300.22(B) and (C).

Please refer to section [Mounting Interface Box](#) for more information on mounting the interface box.

## 3.4 Sensor Grounding Simplified

Please refer to a simplified grounding diagram below for Rev6 and Rev7 OS2 sensors.

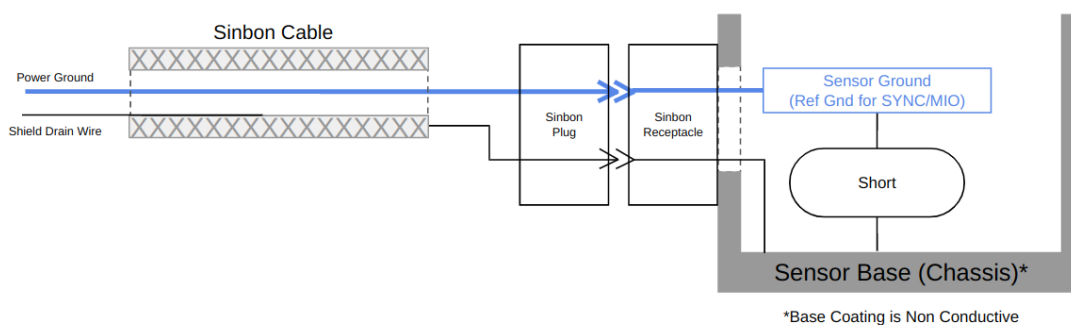

Figure 3.4: Grounding Diagram for both Rev6 and Rev7 OS2 sensors

## 3.5 Operating Temperatures

The sensor has three operating states in order to manage high temperatures: **Active**, **Shot Limiting**, or **Inactive**. In the standard Active state the sensor will perform to the range and precision specifications of the datasheet. When the sensor reaches a certain temperature (see table below for reference), it enters Shot Limiting state and issues an alert.

In Shot Limiting state, the sensor reduces power to the lasers in order to reduce the thermal load. While in this state, sensor range and precision may degrade by up to 20%. When the sensor reaches the maximum operating temperature specified below, the sensor may become Inactive and shut off.

Table 3.3: Maximum thermal performance for Rev7 OS2 Sensor

	Convective Air Temp with Radial Heatsink and Standard Base
Max temp before shot limiting	55°C
Temp that shot limiting saturated (sensor may turn off above this temperature)	61°C

# 4 Electrical Interface

## 4.1 Power Supply and Operating Voltage

The OS2 Sensors are designed to operate between 12V and 24V nominal input voltage. A low voltage warning will be triggered if the voltage at the sensor connector drops below 9.5V. The sensor will shut down if this input voltage drops to 9V. The maximum input voltage is 34V for the OS2 sensor.

When used without the provided interface box, ensure that the power supply is compliant with the operating voltage specified above and is at least 20 W.

**Note:** If operating at cold conditions the peak power consumption is between 22 W and 28 W. Peak power consumption is 28 W if operated at -40°C. Ouster recommends use of power no less than 30W if using in outdoor conditions. Please contact our [Field Application Team](#) can answer your questions and provide guidance for achieving proper operations.

## 4.2 Connection through the Interface Box

The Interface Box that accompanies the OS2 is designed to allow the sensor to be operated for test and evaluation purposes in indoor environments only. It can be connected to the sensor with a cable equipped with connectors. It allows the sensor to be powered up and provides access to the sensor gigabit Ethernet Interface via a standard RJ45 connector. DC Power to the sensor is provided to the Interface Box by the accompanying 24V DC power supply.

## 4.3 Direct Cable Connection and Pinout

The OS2 can be operated without the use of an Interface Box. In this case, a "pigtail" cable should be used by the user following the Pinout presented below. When used with direct cable connection, the sensor should still be operated within the operating voltage specified in section [Power Supply and Operating Voltage](#).

### 4.3.1 Cable Pinout Diagram for Type 1, 2 and 3 (1000BASE-T)

Table 4.1: Type 1, 2, 3 (1000BASE-T)

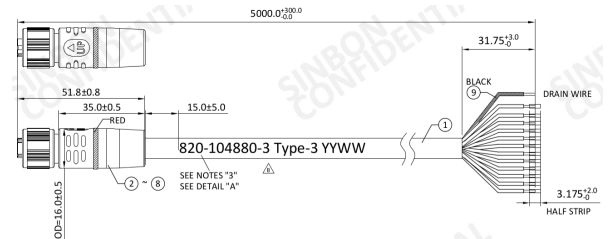
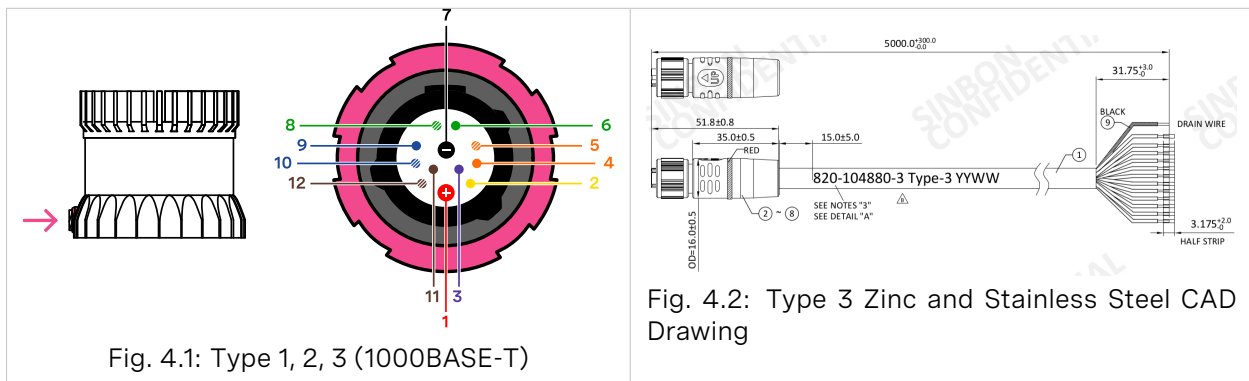







Table 4.2: Pinout and wire gauges for Types 1, 2, and 3 (1000BASE-T) cables

Function	Pin No.	Wire Color	Type-1, 24V	Type-2, 24V	Type-3, 12V	Twisted with	Color (Display)
VCC	1	Red	22 AWG	22 AWG	18 AWG	N/A	
GROUND	7	Black	22 AWG	22 AWG	18 AWG	N/A	
MULTI-PURPOSE_IO	3	Purple	26 AWG	28 AWG	28 AWG	N/A	
SYNC_PULSE_IN	2	Yellow	26 AWG	28 AWG	28 AWG	N/A	
Ethernet BI_DA+	5	White /Orange	26 AWG	28 AWG	28 AWG	Orange	
Ethernet BI_DA-	4	Orange	26 AWG	28 AWG	28 AWG	White /Orange	
Ethernet BI_DB+	8	White /Green	26 AWG	28 AWG	28 AWG	Green	
Ethernet BI_DB-	6	Green	26 AWG	28 AWG	28 AWG	White /Green	
Ethernet BI_DC+	9	Blue	26 AWG	28 AWG	28 AWG	White /Blue	
Ethernet BI_DC-	10	White /Blue	26 AWG	28 AWG	28 AWG	Blue	
Ethernet BI_DD+	12	White /Brown	26 AWG	28 AWG	28 AWG	Brown	
Ethernet BI_DD-	11	Brown	26 AWG	28 AWG	28 AWG	White /Brown	

**Note:** Cable pinout for Type 3 cables are the same for both **Zinc** and **Stainless Steel** connectors. **Type 1** and **Type 2** cable specifications are for reference only are **NO longer available** for purchase.

**Warning:** Ouster is not responsible for any errors in wiring as a result of bypassing the Interface Box and this activity may result in voiding of your warranty if it results in damage to the sensor.

The following guidelines for direct cable connection assume use of the Ouster-provided 24V 1.5A power supply. Ouster cannot be held responsible for damage to the device if an alternate is used.

### 4.3.2 Cable Pinout Diagram for Type 4 (1000BASE-T1)

**Note:** Type 4 (1000BASE-T1) is only applicable for Rev7 (OS0, OS1 and OSDome) Sensors, please use this section only for reference as this is not available for Rev7 OS2 sensor.

Table 4.3: Type 4 (1000BASE-T1)

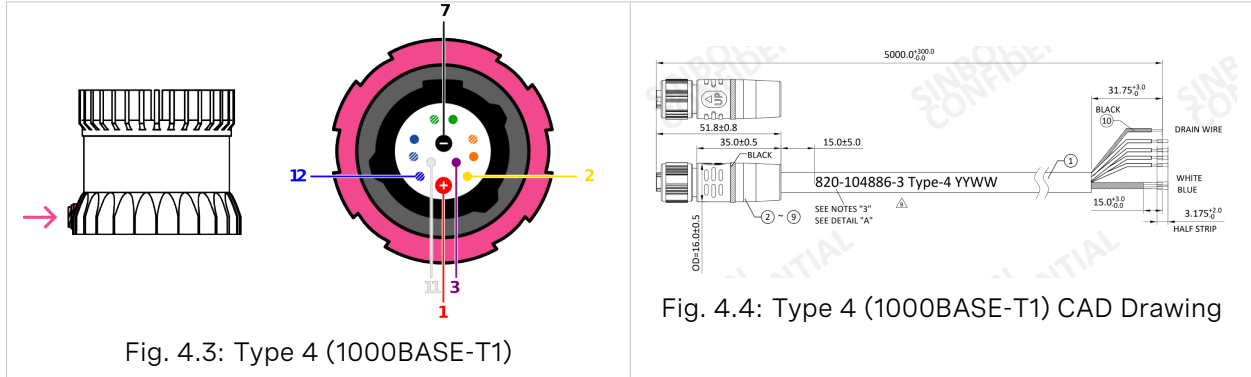







Fig. 4.3: Type 4 (1000BASE-T1)

Fig. 4.4: Type 4 (1000BASE-T1) CAD Drawing

Table 4.4: Pinout and wire gauges for Type 4 (1000BASE-T1) cables

Net Name	Pin No.	Wire Color	Type-4, Base 1000 T1	Twisted with	Color (Display)
VCC	1	Red	18 AWG	NA	
GROUND	7	Black	18 AWG	NA	
MULTIPURPOSE_IO	3	Purple	28 AWG	NA	
SYNC_PULSE_IN	2	Yellow	28 AWG	NA	
Ethernet BI_DA+	12	Blue	26 AWG	White	
Ethernet BI_DA-	11	White	26 AWG	Blue	

**Warning:** Ouster is not responsible for any errors in wiring as a result of bypassing the Interface Box and this activity may result in voiding of your warranty if it results in damage to the sensor.

The following guidelines for direct cable connection assume use of the Ouster-provided 24V 1.5A power supply. Ouster cannot be held responsible for damage to the device if an alternate is used.

# 5 Digital IO

## 5.1 SYNC\_PULSE\_IN

**SYNC\_PULSE\_IN** is a dedicated input channel that is accessible from the Interface Box. This channel expects an input pulse sequence which can be used for time synchronization. Refer to the [Firmware User Manual](#) for more information on configuring this input. Any references to pulse polarity in this document references the signal polarity on the **SYNC\_PULSE\_IN** pin of the sensor. This input channel is protected by an opto-isolator which will draw 5mA at full operation.

Table 5.1: SYNC\_PULSE\_IN Interface Requirements

Parameter	Min Voltage	Max Voltage	Min Driver Current
LOGIC LOW	-30 V	2 V	N/A
LOGIC HIGH	2.9 V	30 V	3mA @3.3V~5V, 5mA at 24V and higher

SYNC\_PULSE\_IN Interface requirements were tested with 2 m cable Interface Box connection at 2 MHz.

- When GPIO has 5 mA drive strength minimum, GPIO can be directly connected to the **SYNC\_PULSE\_IN** pin of the Interface Box header. This is the most common case and has been tested to work on common Arduino microcontroller series. Typical common logic levels of 3.3 V, 5 V GPIO of microcontrollers can produce drive strength of 5 mA min (Arduino, MSP430, etc.).
- If the 5 mA drive strength minimum cannot be met, a buffer circuit is required to drive **SYNC\_PULSE\_IN**. Example circuits are provided for common 3.3 V and 5 V logic.

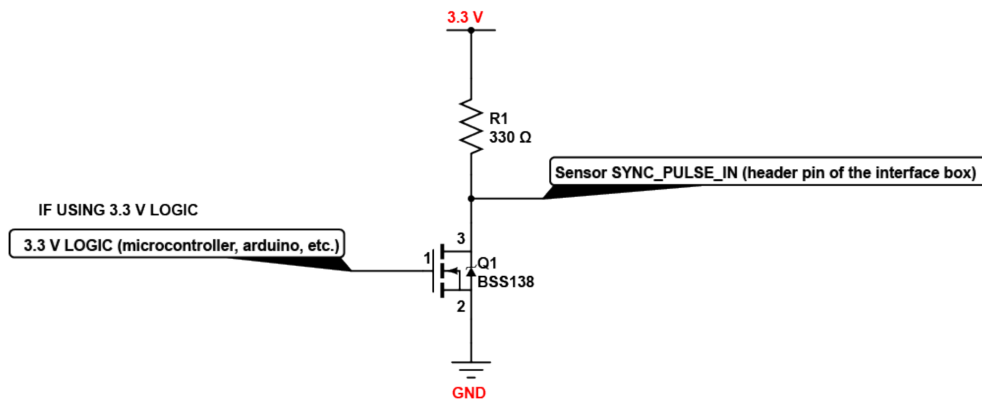

Figure 5.1: Example Circuit for 3.3 V

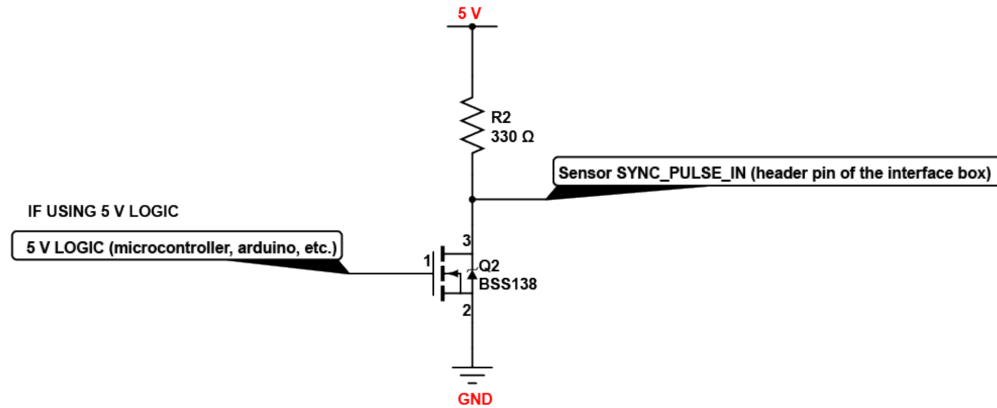

Figure 5.2: Example Circuit for 5 V logic

## 5.2 MULTIPURPOSE\_IO (MIO)

**MULTIPURPOSE\_IO (MIO)** is a configurable input or output channel accessible from the Interface Box. Detailed information on how to configure this channel using the sensor TCP interface can be found in the [API guide](#). By default this channel is disabled.

When this channel is configured as an **OUTPUT**, the **MIO** sends a pulse sequence that can be used for time synchronization or event triggering outside the sensor. For a full description of output pulse triggering options, refer to the [Firmware User Manual](#) for more information. This output is an opto-isolated open collector circuit, relying on an externally provided pull-up resistor. This resistor is provided for a typical 3.3V/5V application as part of the Interface Box circuitry.

Table 5.2: MULTIPURPOSE\_IO - OUTPUT Interface Requirements

Parameter	Min	Max
Pull Up Voltage	3.3 V	24 V
Sinking Current	N/A	25 mA

When this channel is configured as an **INPUT**, the **MIO** can accept a standard NMEA \$GPRMC UART message. These messages are a common way for GPS systems to share timestamp information in UTC time format. More information on this packet structure and supported baud rates can be found in the [Time Synchronization](#) section of the [Firmware User Manual](#).

Table 5.3: MULTIPURPOSE\_IO - INPUT Interface Requirements

Parameter	Min Voltage	Max Voltage	Min Driver Current
LOGIC LOW	-30 V	2 V	N/A
LOGIC HIGH	2.9 V	30 V	3mA @3.3V~5V, 5mA at 24V and higher

*Above are tested with a 35m (200uH inductance) Interface Box at 115200 Baud.*

## 6 OS2 CAD files

---

The most up-to-date CAD files of all our products can be found on our [Lidar Product Details](#) page.

## 7 Accessories

---

### 7.1 Cables

---

4 Types of cables are compatible with the OS2 sensors.

The cable and plug are an element of the sensor ingress protection. Without this, the ingress protection rating may be compromised.

Bending the cable at a sharp angle directly after egress from the plug over mold should also be avoided. Sharp bends and high axial stresses on the cable immediately adjacent to the plug over mold may create a moisture ingress path into the connection. Please note the cable minimum bend radius requirements here [Cable Characteristics](#).

The recommended cable bend radius is 5 X O.D (O.D = outer diameter of the cable) for applications where the cable is static, or non-moving. Please observe a minimum bend radius of 10 X O.D for installations where the cable is frequently moving. The maximum cable length recommended by Ouster is 30m.

---

**Note:** For Rev 06 and prior sensor, Ouster requires the users to use Type 3 cables with Zinc connectors. For Rev6.2 and later sensors, use Type 3 cables with Stainless Steel connectors. If you need 1000BASE-T1 Single-Pair Ethernet (SPE), use Type 4 cables.

We no longer offer Type 1 and Type 2 cables for sale. Please contact [Ouster sales](#) for questions regarding available cable lengths, connector types, and termination options.

---

**Warning:** User must make sure to use a zinc connector cable if the sensor has a zinc connector on it, a stainless steel connector cable if the sensor has a stainless steel connector on it. If you have any questions regarding the type of cable or connector you have please contact [Ouster Support](#).

## 7.1.1 Cable Characteristics

**Note:** Type 4 (1000BASE-T1) is only applicable for Rev7 (OS0, OS1 and OSDome) Sensors, please use this section only for reference as this is not available for Rev7 OS2 sensor.

Table 7.1: Cable Characteristics

Cable	Outer Diameter	Cable (Static)	Minimum Bend	Cable Minimum Bend (Flexible)
Type 1 (Thick)	10.5mm	79mm		158mm
Type 2 (Thin)	8mm	40mm		80mm
Type 3 (High Current)	8.2mm	41mm		82mm
Type 4 (1000BASE-T1)	7.5mm	37.5mm		75mm

**Note:** Type 3 Cable has an imprint that states "Type 3" on it whereas, Type 2 & Type 1 do not have any identifiers.

**Note:** Ouster recommends using a right angled connector cable for use cases wherein the cable needs to be bent within the first **5 cm** between the connector and the rest of the cable.

## 7.1.2 Electrical Characteristics (POWER and GROUND wires)

Ouster has characterized the cable resistance and contact resistance of our cables at room temperature. This can be found below:

Table 7.2: Electrical Characteristics (POWER and GROUND wires)

Cable	Maximum Cable Resistance ( $\Omega/m$ )	Typical End to End Resistance for 5m Cable ( $\Omega$ )	Admissible Nominal Operating voltage (V)
Type 1 (Thick)	0.110	0.45	24
Type 2 (Thin)	0.110	0.45	24
Type 3 (High Current)	0.042	0.3	9 - 34
Type 4 (1000BASE-T1)	0.042	0.3	9 - 34

For full sensor functionality, a minimum of 9.0 V must reach the sensor and the maximum allowed operating voltage is 34 V. To compensate for losses through wire resistance, a higher voltage must be provided to the interface end of the cable, which may be the Interface Box or the pigtail wires. If the sensor is below this voltage for at least 1 second, the INPUT\_VOLTAGE\_LOW error will be triggered.

The following graph *Voltage at connector vs cable length* can be used as a guide to determine the appropriate input voltage to the sensor connector for your desired cable length. The values on the graph were calculated using idealized cable resistances derived from the AWG system and assumed maximum power draw from the sensor.

---

**Note:** For Type 4, please refer to Type 3 (18 AWG) in the graph below as they have the same electrical characteristics.

---

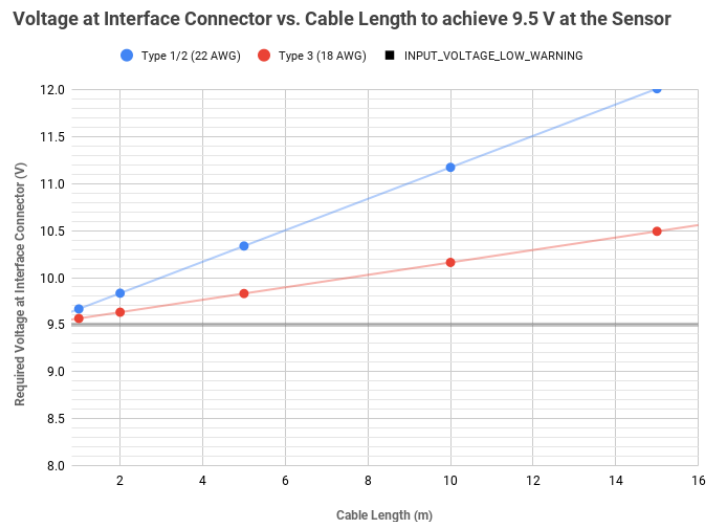

Figure 7.1: Voltage at connector vs cable length

## 7.2 Interface Box

---

All Interface Boxes are provided with a DC power port and an RJ45 jack for Ethernet. Currently Ouster offers two types of Interface boxes to support both 12V and 24V.

Legacy 24V nominal Interface Boxes provided with Type 1 and Type 2 cables are assembled with integral cables for connection to Ouster’s sensors.

12V/24V nominal Interface Boxes with Type 3 cables are provided in modular and integral cable variants. The modular variant has a built-in connector and a detachable double-connectorized Type 3 cable for connection to Ouster’s sensors. Whereas, the integral cable variant which is our current **“STANDARD”** are not detachable and have only one sided connector. Both variants have a GPS connector capable of accepting TTL level signals originating from a separate GPS device that contains ESD protection circuitry.

---

**Note:** Both Legacy and Modular interface boxes are no longer available for purchase, it has been mentioned in this user manual for reference/information only for existing users. Please contact [Ouster sales representative](#) for questions regarding available options.

---

**Example:** GPS Module compatible with Ouster Sensor [GPS Module](#). If you need support to configure the GPS to works with our sensor please contact [support@ouster.io](mailto:support@ouster.io).

**Warning:** RISK OF FIRE OR ELECTRIC SHOCK. DO NOT CONNECT THE GPS CONNECTOR DIRECTLY TO AN ANTENNA.

### 7.2.1 Interface Box (Important Notice)

The Ouster Interface Box is a support tool for use in laboratory environments to assist customers in evaluating Ouster's lidar sensor products and in the development of software. The Interface Box is not protected from ingress of moisture or solid particles and is not intended for use outdoor.

The Interface Box has a top cover affixed using 4 self-tapping screws. The cover may need to be removed in order to set the operating modes or to change the fuse. The plastic that the self-tapping screws fasten into is delicate, please remove and replace the screws slowly and carefully. When multiple attempts are made to remove the screws, the mounting posts may be stripped.

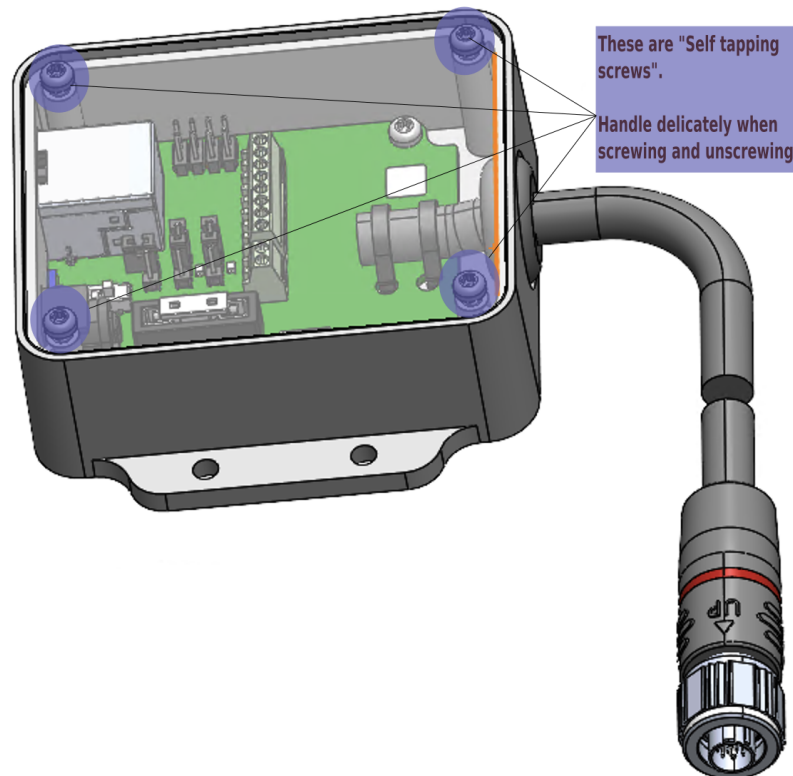

Figure 7.2: Warning on Self Tapping Screws

## 7.2.2 Types and Physical Characteristics

A list of all Ouster provided interface boxes are provided for reference below. Please contact [Ouster Support](#) if you have any further questions.

Product Name	Part Number	Cable Type	Connector Material	Cable Length (m)	Connector Angle (°)	PCBA PN	
Legacy Interface Box with Type 1 Cable	840-101615	Type 1 (Heavy)	Zinc	5	Straight	830-101798	
	840-102058			8.5			
	840-102065			9.5			
	840-102047			10			
	840-102066			15			
	840-102067			30			
Legacy Interface Box with Type 2 Cable	840-102068	Type 2 (Light)		1			
	840-102069			2			
	840-101986			5			
	840-102061			10			
	840-102070			15			
	840-102833			20			
	840-102064			30			
	840-102910			40			
	840-102850			1			0
	840-102071						90
	840-102072						180
	840-102079						270
	840-102080			5			0
	840-102081						90
	840-102082						180
	840-102083						270
	840-102827			10			0
	840-102828						90
	840-102829		180				
	840-102830		270				
840-102867	15	0					
840-102868		90					
840-102869		180					
840-102870		270					
High Current Interface Box with Type 3 Cable & Zinc Connector	840-105337	Type 3 (High Current)	1	Straight	830-104249		
	840-105338		5	Straight			
	840-105339		10	Straight			
	840-105340		15	Straight			
	840-105341		5	90			
	840-105342			180			
840-105343	270						
High Current Interface Box with Type 3 Cable & Stainless Steel Connector	840-105282		Stainless Steel	1		Straight	
	840-105283			5		Straight	
	840-105284			10		Straight	
	840-105285			15		Straight	
	840-105286			5		90	
	840-105287	180					
	840-105288	270					
High Current Modular Interface Box	840-103284	None	Zinc	N/A	N/A	830-103125	

Figure 7.3: Types of Interface Boxes

### 7.2.3 High Current Interface Box (PCBA 830-104249) - Standard

This is a 12V/24V nominal Interface Box with Type 3 cable available with either zinc or stainless steel connectors. This interface box has a GPS connector capable of accepting TTL level signals originating from a separate GPS device that contains ESD protection circuitry.

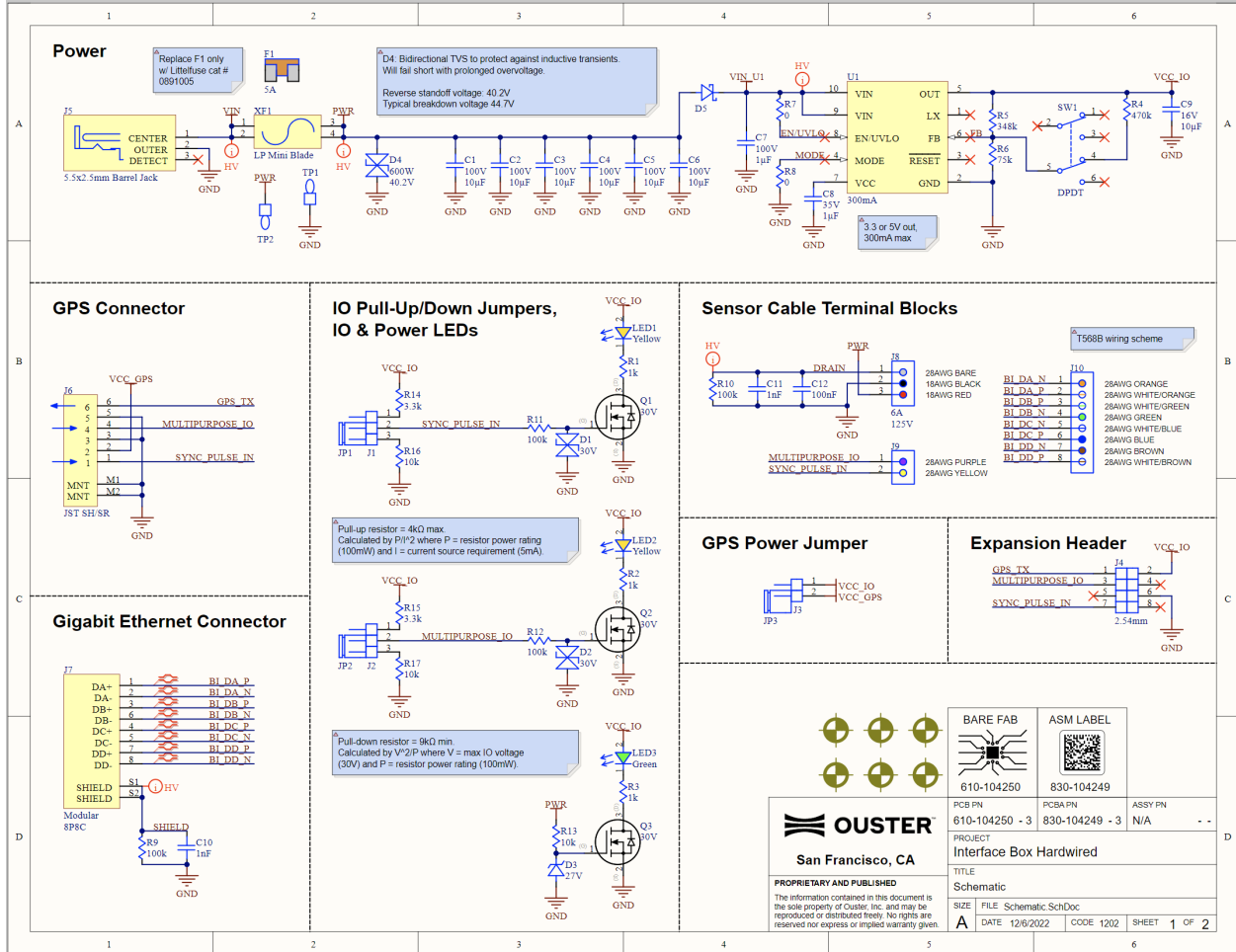
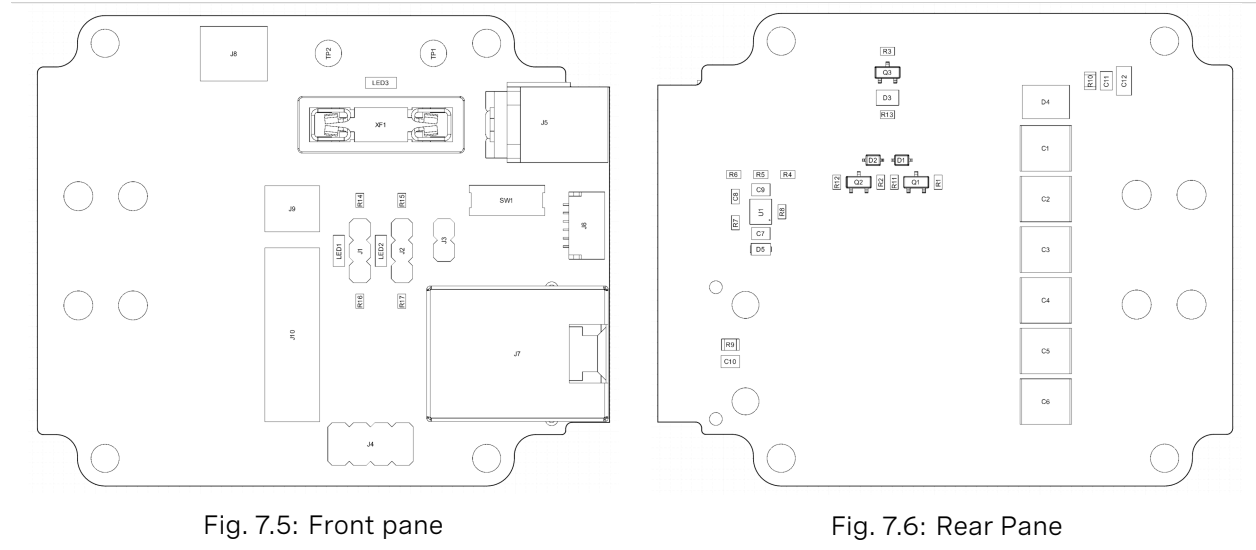

Figure 7.4: Interface Box Schematic Diagram

### 7.2.3.1 Cable Connection and Pinout

The OS2 can be operated without the use of an Interface Box. For more information on the Ouster Cable Pinout please refer to [Direct Cable Connection and Pinout](#).

Table 7.3: Interface Box Connection Diagram (PCBA PN- 830-104249)



### 7.2.3.2 Specification

- Gigabit ethernet RJ45 jack (1000BASE-T).
- VIN Barrel Jack. Use with a 5.5mm OD x 2.5mm ID barrel plug.
- User replaceable 5A fuse. Use only **Littlefuse #0891005**.
- VIN green LED indicator.
- Onboard buck power supply generating VCC\_IO. VCC\_IO supplies the onboard LEDs and pullups, and is user accessible via headers J3 & J4. Switch SW1 is used to select the buck’s output voltage. WARNINGS: Max allowable user consumption is 210mA. Ensure power to the Interface Box is disconnected when changing buck output voltage via SW1.
- 10kΩ pull-downs, 3.3kΩ pull-ups to VCC\_IO, and yellow LED indicators for SYNC\_PULSE\_IN and MULTIPURPOSE\_IO. Install a jumper on the respective header (J1 or J2) to enable the pull-down or pull-up.
- 0.1” pitch, 4x2 pin header J4. GPS\_TX (Pin 1) is only connected to connector J6; it is not connected to the sensor.
- 6-pin JST SH/SR connector J6. VCC\_GPS (Pin 2) is connected to VCC\_IO by installing a jumper on header J3. GPS\_TX (Pin 6) is only connected to header J4; it is not connected to the sensor.

## 7.2.4 High Current Modular Interface Box (PCBA PN- 830-103125)

This type of interface box is designed for users who require the use of a lower voltage power supply, such as 12V (as long as the sensor also supports a wide input voltage range). These interface boxes also have a new GPS input connector capable of accepting TTL level signals that originate in a separate GPS device that contains an ESD dissipation circuit.

Table 7.4: Interface Box Connection Diagram (PCBA PN- 830-104249)

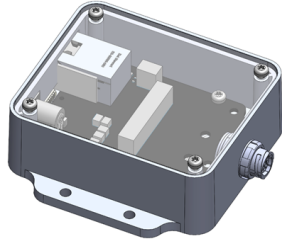

Fig. 7.7: Interface Box 12V Design

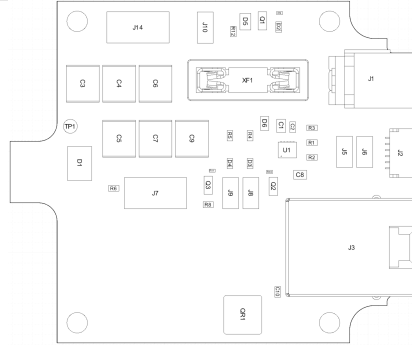

Fig. 7.8: Modular Interface Box Connection Diagram (PCBA PN- 830-103125)

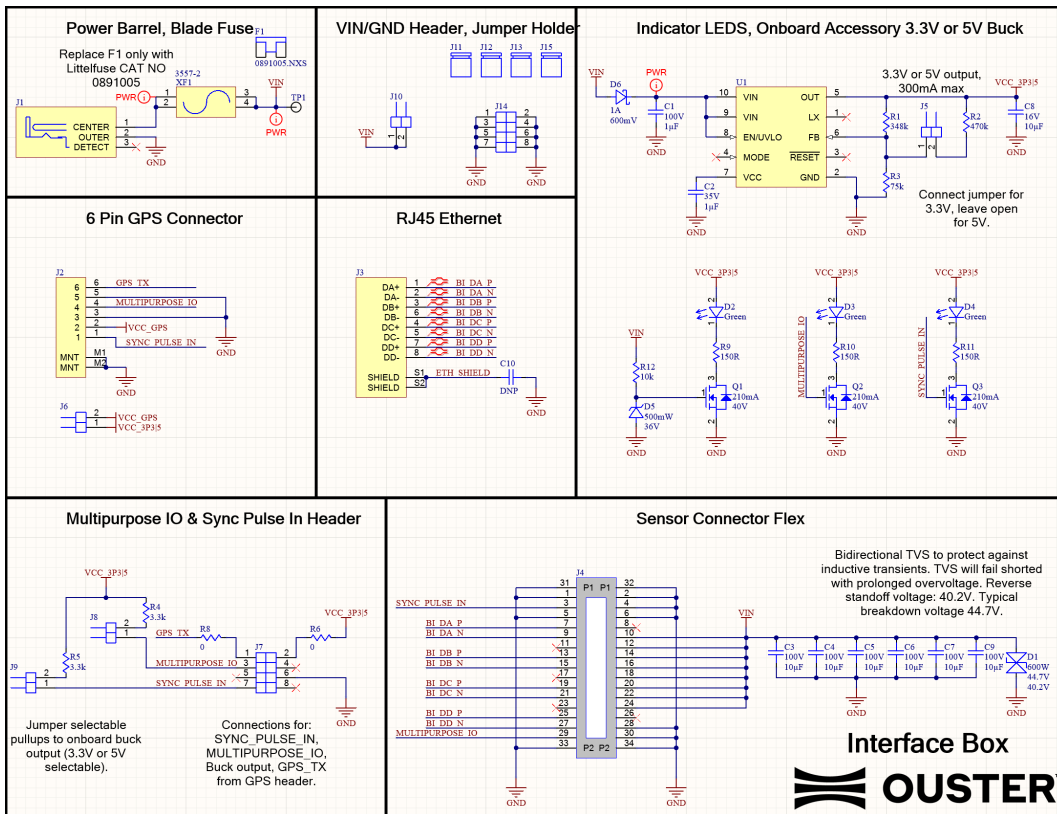

Figure 7.9: Modular Interface Box Schematic Diagram

### 7.2.4.1 Specification

- Gigabit ethernet RJ45 jack (1000BASE-T).
- VIN Barrel Jack. Use with a 5.5mm OD x 2.5mm ID barrel plug.
- User replaceable 5A fuse. Use only **Littlefuse #0891005**.
- VIN green LED indicator, fuse-protected VIN header (J10) and Ground header / jumper storage (J14).
- Onboard buck power supply generating VCC\_3P3|5. VCC\_3P3|5 supplies the onboard LEDs and pullups, and is user accessible via headers J2 & J7. Header J5 is used to select the buck's output voltage: install a jumper for 3.3V, leave open for 5V. WARNINGS: Max allowable user consumption is 210mA. Ensure power to the Interface Box is disconnected when changing buck output voltage via J5.
- 3.3k $\Omega$  pullups to VCC\_3P3|5 and green LED indicators for SYNC\_PULSE\_IN and MULTIPURPOSE\_IO. Install a jumper on the respective header (J9 or J8) to enable the pullup.
- 0.1" pitch, 4x2 pin header J7. GPS\_TX (Pin 1) is only connected to connector J2; it is not connected to the sensor.
- 6-pin JST SH/SR connector J2. VCC\_J2 (Pin 2) is connected to VCC\_3P3|5 by installing a jumper on header J6. GPS\_TX (Pin 6) is only connected to header J7; it is not connected to the sensor.

---

**Note:** This interface box is no longer available for purchase and is specified in this manual only for reference for existing users. This is optional for Rev 06 Sensors and above and is compatible with Type 3 double-ended Cables only.

---

### 7.2.5 Interface Box 24V (Legacy Type 1 and Type 2)

For more information on this please refer to Rev 06 or prior [Hardware User Manuals](#).

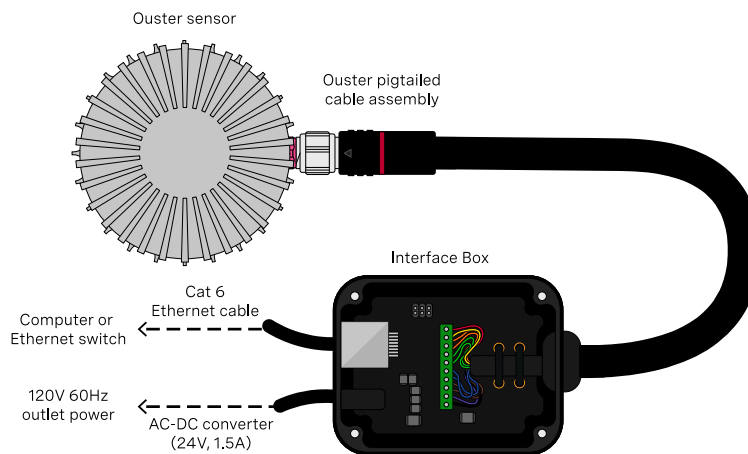

Figure 7.10: Sensor-Interface box connectivity

**Note:** Ouster no longer offers **Type 1** & **Type 2** cables. Please contact [Ouster sales](#) for questions regarding available cable types, lengths, connector types, and termination options.

## 7.2.6 Connectors

Connectivity Guide:

- 8P8C "RJ45" Jack: Gigabit ethernet connection
- 6-Pin JST SH/SR: Connector for external GPS
- 5.5 x 2.5mm Barrel Jack: DC power input

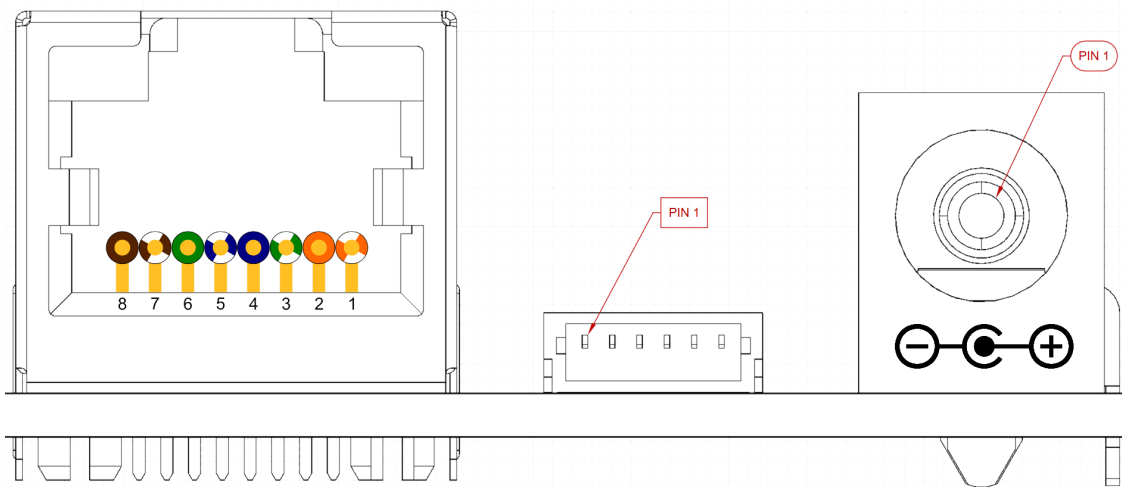

Ethernet RJ45 Connector Pinout			
Pin	Function	T568B Color	T568B Pair
1	Ethernet BI_DA+	White/Orange	2
2	Ethernet BI_DA-	Orange	2
3	Ethernet BI_DB+	White/Green	3
4	Ethernet BI_DC+	Blue	1
5	Ethernet BI_DC-	White/Blue	1
6	Ethernet DI_DB-	Green	3
7	Ethernet BI_DD+	White/Brown	4
8	Ethernet BI_DD-	Brown	4

GPS JST SH/SR Connector Pinout			
Pin	Function	Direction	GPS Connection
1	SYNC_PULSE_IN	In to I-Box	PPS Out
2	VCC_GPS (can be connected to VCC_IO via jumper inside I-Box)	Out of I-Box	VCC (Optional)
3	GND	-	GND
4	MULTIPURPOSE_IO	In to I-Box	NMEA Out
5	GND	-	GND
6	GPS_TX (connected to header inside I-Box)	-	Optional

5.5 x 2.5mm Barrel Jack		
Pin	Description	Function
1	Center Pin (Tip)	Power
2	Outer Ring (Sleeve)	Return
3	Insertion Detection	Not Used

Figure 7.11: Connector Outline

## 7.3 Mounting Interface Box

The interface box may be mounted on a table top or on a wall (or similar vertical surface). Use not less than two (2) screws (M4 SHCS 10mm or longer are recommended) to secure the interface box to the mounting surface.

### 7.3.1 High Current Modular Interface Box (PCBA PN- 830-103125)

Table 7.5: Mechanical Drawing - High Current Modular Interface Box (PCBA PN- 830-103125)



Table 7.6: Mechanical Drawing - High Current Modular Interface Box (PCBA PN- 830-103125) (cntd.)

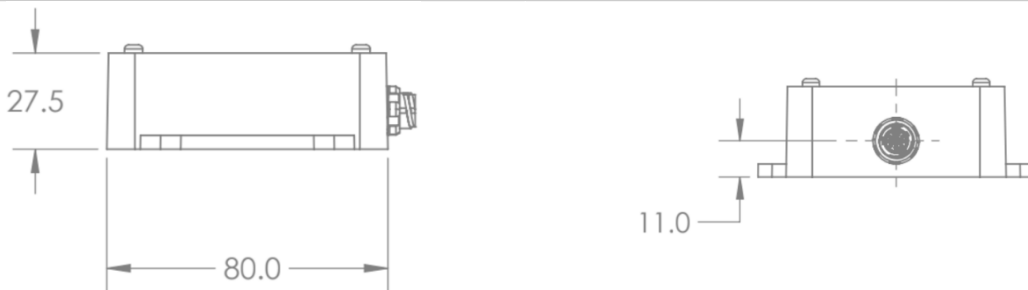

**Note:** This type of interface box is **NO longer available** for purchase and are specified in this document for reference only for users who already have them.

### 7.3.2 High Current (12 or 24V) Interface Box (PCBA 830-104249) - Standard

Table 7.7: Mechanical Drawing- Interface Box (PCBA PN- 830-104249)

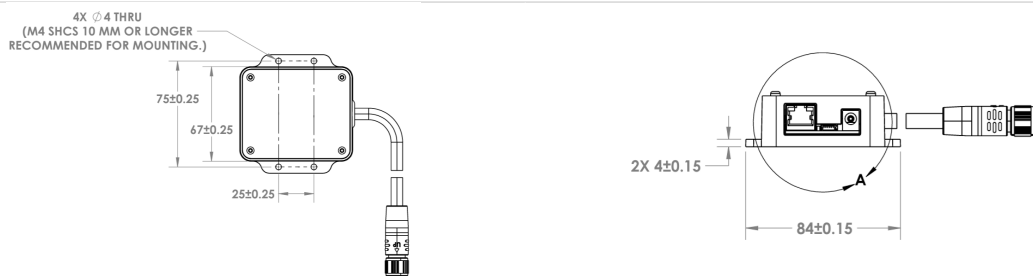
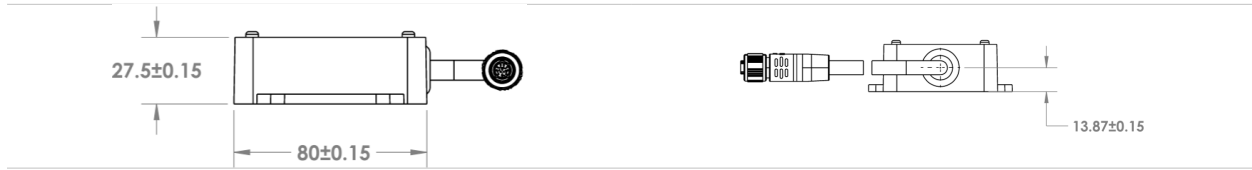

Table 7.8: Mechanical Drawing- Interface Box (PCBA PN- 830-104249) (cntd.)



For additional OS2 sensor CAD files refer to [Lidar Product Details](#) page.

### 7.3.3 Electrical Characteristics

High Current Interface Boxes are rated 12VDC, 3.3A and 24VDC, 1.1A. They support 24V operation on all Ouster sensors, and 12V operation for Rev5 and above sensors only.

Legacy Interface Boxes are rated 24VDC, 1.1A and supports all Ouster sensors.

### 7.3.4 Over-current Protection

High Current Interface Boxes contain a user replaceable 5A low-profile mini blade fuse. When replacing this fuse, use only a Littelfuse #0891005 fuse. Use of any other fuse may lead to a risk of fire.

Legacy Interface Boxes are provided with thermistor type over-current protection to supplement the internal over-current protection in the sensor. The thermistor is soldered in place and is not user replaceable.

## 7.4 Power Supply

The Interface Box ships with a 24VDC 1.5A power supply and a cord set suitable for use in the U.S.A and Canada. High Current Interface Boxes are able to operate from a 12VDC source, but a 12VDC power supply is not provided by Ouster.

Legacy Interface Boxes are only designed for use with the supplied 24V power supply.

To select a power supply, it should:

- have a 12VDC output voltage rating.
- be capable of delivering at least 3.3A.
- be identified or marked as having a Limited Power Source (LPS) output.
- be safety certified by an acceptable test house in the local region of use using either IEC 60950-1 or IEC 62368-1 (or the EN or other national equivalent).
- be provided with a power supply cord set appropriate for the power supply's input and the socket outlets available in the lab space.
- be provided with a standard 5.5 x 2.5mm center-positive barrel connector.

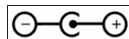

### 7.4.1 Selecting a Power Supply Cord/Cord-set

If purchasing a power supply locally, it should be supplied with an appropriate power supply cord or cord-set for use with the power supply.

If it's necessary to select a power supply cord-set for the Ouster supplied power supply, it should be safety certified by a test house acceptable to the local region of use, supplied with an IEC 60320, Type C6 cord connector to mate with the power supply and a plug for connection to an AC outlet with an earthing contact/pin.

### 7.4.2 Environmental Ratings

All Interface Boxes are suitable for use indoors only in clean, protected environments at temperatures between -20 °C and +50 °C. Interface Boxes are not designed for use outdoors or in environments that are not protected from dust, moisture, or high humidity.

## 8 GPS/GNSS Synchronization Guide

---

This guide will explain how to physically connect a GPS to your Ouster sensor and synchronize the Ouster sensor timestamp to an NMEA sentence.

### 8.1 Setting up your GPS/GNSS

---

It is important to ensure you have configured your GPS according to the manufacturer's specifications.

The Ouster sensor accepts the following:

- NMEA sentence type: **GPRMC** only (future support for other sentence types)
- Baud Rates: **9600** or **115200**
- Polarity: Normal or Reversed (**ACTIVE\_HIGH**<sup>1</sup> or **ACTIVE\_LOW**<sup>2</sup>)
- Voltage: **3.3 - 15 V** logic with a minimum drive current of **5 mA**.
  - If your GPS can't meet these minimums you will need to buffer the voltage with an additional circuit. Details in the [Digital IO](#) section of the Ouster Hardware User Manual.

**1** **ACTIVE\_HIGH**- Low to high edge as critical timing event

**2** **ACTIVE\_LOW**- High to low edge as critical timing event

---

**Note:** Once you have configured your GPS, it is good practice to verify the signals using an oscilloscope. This will ensure you have the correct baud rate, polarity, voltage, and message type being output.

---

## 8.2 Connecting the Hardware

The next step to successfully connecting your GPS is ensuring that you have connected the outputs from your GPS to the correct inputs of the sensor.

### 8.2.1 Connection using the GPS Port

- Connect the PPS output from your GPS to the sync\_pulse\_in pin of the GPS connector to be plugged on the Ouster Interface Box.
- Connect the NMEA UART output from your GPS to the multipurpose\_io pin of the GPS connector to be plugged on the Ouster Interface Box.
- Connect the ground output from your GPS to the GND pin of the GPS connector to be plugged on the Ouster Interface Box.

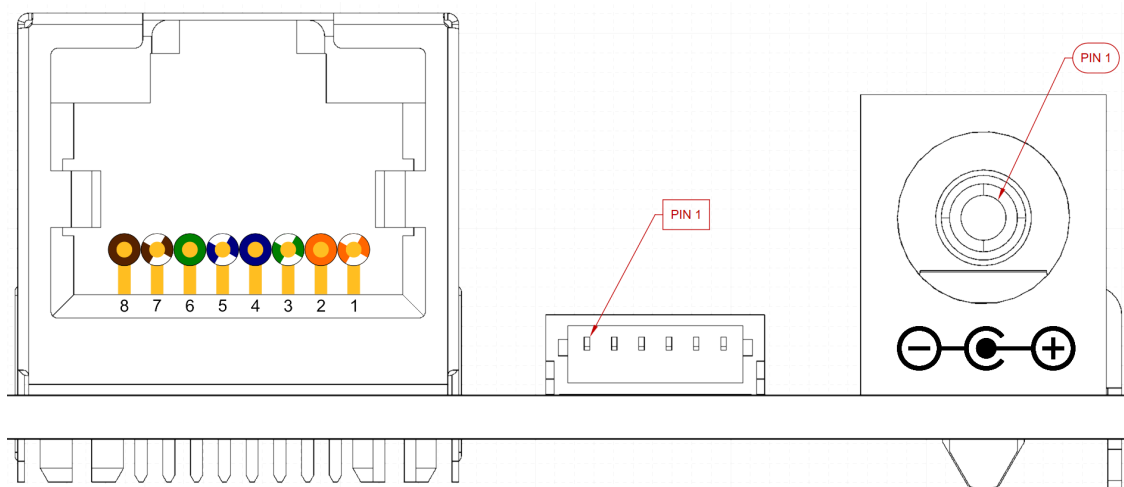

**Ethernet RJ45 Connector Pinout**

Pin	Function	T568B Color	T568B Pair
1	Ethernet BI_DA+	White/Orange	2
2	Ethernet BI_DA-	Orange	2
3	Ethernet BI_DB+	White/Green	3
4	Ethernet BI_DC+	Blue	1
5	Ethernet BI_DC-	White/Blue	1
6	Ethernet BI_DI_DB-	Green	3
7	Ethernet BI_DD+	White/Brown	4
8	Ethernet BI_DD-	Brown	4

**GPS JST SH/SR Connector Pinout**

Pin	Function	Direction	GPS Connection
1	SYNC_PULSE_IN	In to I-Box	PPS Out
2	VCC_GPS (can be connected to VCC_IO via jumper inside I-Box)	Out of I-Box	VCC (Optional)
3	GND	-	GND
4	MULTIPURPOSE_IO	In to I-Box	NMEA Out
5	GND	-	GND
6	GPS_TX (connected to header inside I-Box)	-	Optional

**5.5 x 2.5mm Barrel Jack**

Pin	Description	Function
1	Center Pin (Tip)	Power
2	Outer Ring (Sleeve)	Return
3	Insertion Detection	Not Used

Figure 8.1: Connector Outline

### 8.2.2 Connection using the Pin out

- Connect the PPS output from your GPS to the sync\_pulse\_in pin of the Ouster Interface Box.
- Connect the NMEA UART output from your GPS to the multipurpose\_io pin of the Ouster Interface Box.
- Connect the ground output from your GPS to the GND pin of the Ouster Interface Box.

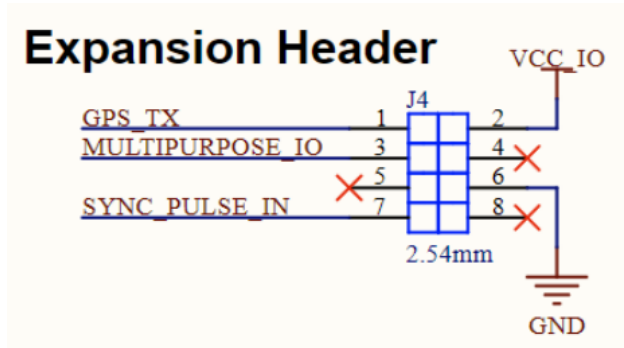

Figure 8.2: Header Pin out

Based on the type of interface box being used please refer to either [Modular Interface Box Schematic Diagram](#) or [High Current Interface Box \(PCBA 830-104249\) - Standard](#).

Table8.1: SYNC\_PULSE\_IN Interface Requirements

Parameter	Min Voltage	Max Voltage	Min Driver Current
LOGIC LOW	-30 V	2 V	N/A
LOGIC HIGH	2.9 V	30 V	3mA @3.3V~5V, 5mA at 24V and higher

Table8.2: MULTIPURPOSE\_IO - INPUT Interface Requirements

Parameter	Min Voltage	Max Voltage	Min Driver Current
LOGIC LOW	-30 V	2 V	N/A
LOGIC HIGH	2.9 V	30 V	3mA @3.3V~5V, 5mA at 24V and higher

## 8.3 Configuring the Ouster Sensor

---

Please refer to the [GPS configuration](#) section in the firmware user manual to configure your sensor to synchronize its timestamp with the GPS.

# 9 Support

---

In case of any questions regarding the contents of this user manual or the configuration of the sensor, please contact [Ouster Support](#) or visit [Ouster website](#).