

**Approximate Operating Distances (mm)
on Non Ferrous Surfaces**

X	Min Close	36mm
	Max Open	65mm
Y	Min Close	27mm
	Max Open	60mm

Mounting on a ferrous surface will reduce these figures, dependant on the material and thickness.

Specifications			
Switch	Housing		
Contact Material:	Rhodium	Material:	High Impact Polystyrene
Contact Rating:	500mA @ 12Vdc	Contact Dimension (mm):	85 x 25 x 21
Contact Resistance:	100 milliOhms	Contact Fixing (mm):	72mm centres
Temperature Range:	-15° C to +40° C	Magnet Dimension (mm):	85 x 18 x 21
Life Expectancy:	>1,000,000 cycles	Magnet fixing (mm)	40 centres

Environmental Advice.

This product is covered by current WEEE regulations. Please consider the effect on the environment when disposing of it. Do not put in a domestic waste bin. Only dispose of at an appointed recycling centre.



RoHS compliant.

This product is designed to meet the requirements of EN50131-2-6:2008 Security grade 2, environmental class II

SC570*/G2/EN Magnetic Surface Contact.

* colour varies



Surface mounted magnetic contact.
6 terminals.
Seperate tamper circuit.
Suitable for domestic and commercial alarm circuits.
Suitable for double door applications.
Can be used in installations up to and including grade 2.
High impact polymer construction.

Operating and Installation Instructions

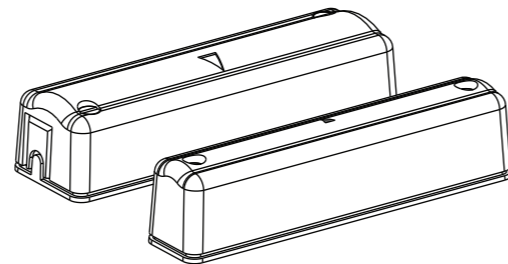

Description

This contact is a modern stylish magnetic door contact that can be used in most security systems up to and including grade 2 as specified in EN50131-1: 2006 and is certified to EN50131-2-6:2008 and environmental class II (for use indoors) by Telefication. It operates as a normally closed circuit going open when the magnet housing is moved away from the contact housing. This contact can be used on windows and doors to detect the unauthorised entry of an intruder. A number of applications are shown below. The contact is also protected against tampering with the additional option of detection of removal from its mounting surface if required.

CQR Security, 125, Pasture Road, Moreton, Wirral. CH46 4TH, United Kingdom
Tel: +44 (0) 151 606 9595 Support: +44 (0) 151 606 6311 email: info@cqr.co.uk Web http://www.cqr.co.uk

Features

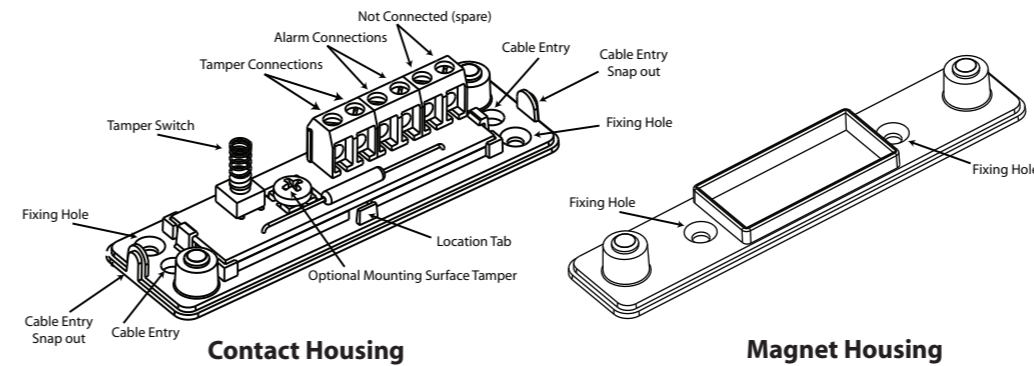

Suitable Applications and Fixing Points

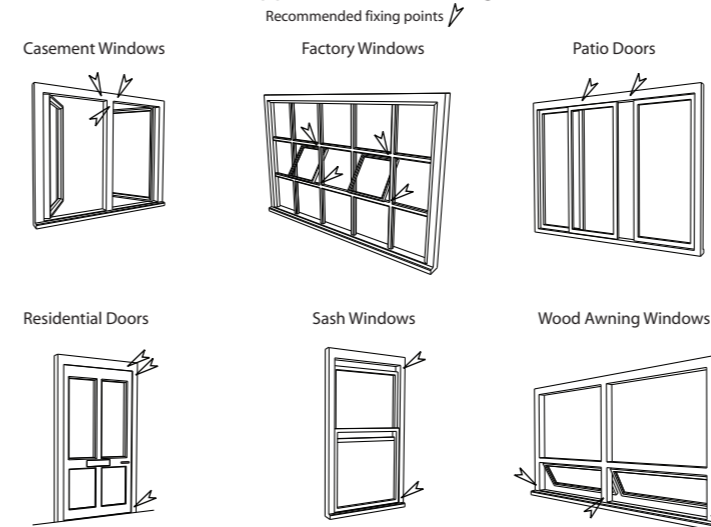

Mounting Instructions

Mount the contact housing using the fixing holes as shown in the diagram. Please see the mounting configurations to ensure that the contact is mounted in the most suitable configuration for the location. Please note that the location tab on the contact housing indicates the direction towards the magnet case. If removal from wall tamper is required, use the extra screw provided and insert into the hole as shown. This is designed to break the circuit board and is irreversible. Please note that in the case of forcible removal from the wall, the contact will need to be replaced. Two cable entries are provided at either end, snap out the appropriate section to allow for the cable entry. There are also holes at either end to allow for rear cable entry, as well as a hole behind the circuit board. To remove the circuit board, carefully pull back the retaining clips to release the board. To refit, reverse the procedure. Mount the magnet housing by removing the cover and use the two available screw holes.

Mounting Configurations

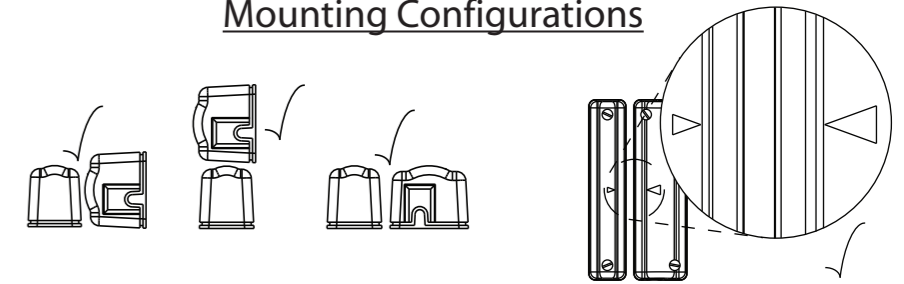

Wiring Configurations

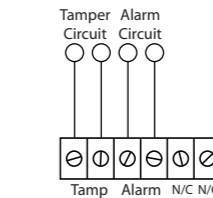

Double pole configuration

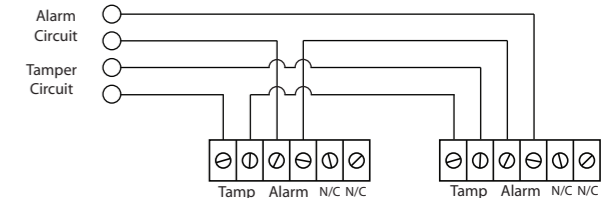

Door 1
Door 2
Double pole, double door configuration

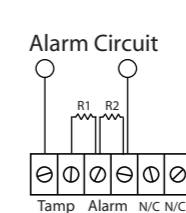

Alarm Circuit
Fully supervised configuration.
R1 and R2 to suit the control panel.

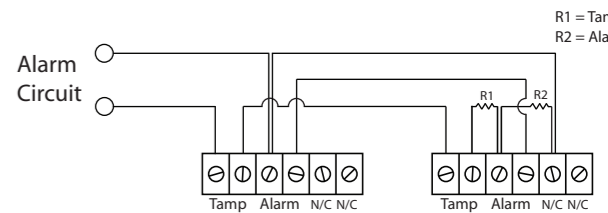

Alarm Circuit
Fully supervised, double door configuration, R1 and R2 to suit control panel