

Please read these instructions fully before installation.

SDTRAPPER Intelligent Shock Detector

Installation Instructions

Specification

Supply Voltage	9 - 30 volts DC
Quiescent Current	17mA at 12 volts DC
Alarm Current	11mA at 12 volts DC
Operating Temp	-20 to +50 degrees centigrade
Indication	Tri-Colour LED Red = Alarm Amber = Engineer Green = Day
Alarm Relay	Normally closed, open in alarm (3 seconds)
Alarm Relay Rating	150mA at 24V 10 ohm 0.25W resistor in series
Tamper Switch	Normally , open on lid removal
Tamper Rating	50mA at 12V
Alarm Memory	Up to 10 Trappers with individual annunciation.
Slave Sensors	Up to 2 CQR shock sensors and/or magnetic contacts.
Dimensions	21mm x 25mm x 92mm

V3: 20191202

Explanation of Features

Time Integrated Pulse Count Analysing System.

The alarm threshold may be reached by either a single shock signal of the required magnitude or by an accumulation of multiple shocks of varying sizes within the time window.

The length of the time will be automatically set by the magnitude of the first shock. If the initial shock is small, so too will the time window. If the initial shock is large, the time window will also be large (up to 60 seconds).

This ensures that small signals which are likely to be caused by birds, trees etc are quickly ignored and do not accumulate to an alarm level, whilst larger or more frequent shocks which are more likely to be intrusion attempts, are validated and stored in the pulse count memory.

Engineer Selectable Features

- Shock strength analysis and indication, (via amber LED)
- Quiet and confidence modes, (flashing green LED)
- Alarm memory latch with sequential recall (up to 10 units)

Fitting and Assembly

Locate the Trapper base referring to Fig 1. and Fig 2. overleaf.

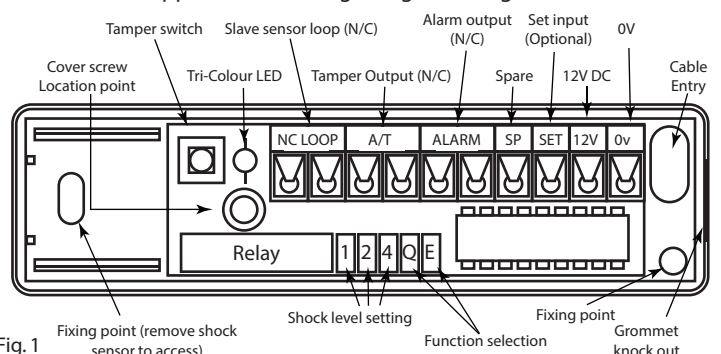
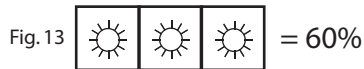

Fig. 1

- Firmly strike the outer limits of the protected surface, using a hard object, refer back to Fig. 6.
- After 3 seconds the LED will flash amber to indicate level of shock received.
1 flash = 20% of an alarm, 2 flashes = 40%,
3 flashes = 60% (as in Fig. 13), 4 flashes = 80%, red = alarm.



- Ideally the LED should give 3 or 4 flashes, assuming a single large shock almost sufficient to cause a breakage to the protected surface.
- If LED shows red, reduce the sensitivity, if less than 3 amber flashes, increase the sensitivity using the jumper plugs. i.e 1+4=5 or 1+2=3. Remove link "E"
An alarm detection is not normally required unless the protected material is actually broken.

Alarm Memory Control

- Connect in parallel, the "set" of each trapper (up to 10) and then connect the set line, via a 1K resistor (provided) to the control panel "set"/"latch" output as in Fig. 14.

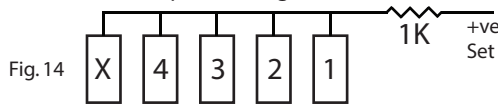

- Ensure that the control panel set output goes high when the system is set.
- While the system is set, the trapper(s) will not give any LED indication.
- Activation will cause the alarm relay to operate.
- Any alarm activations while the system is set, will be memorised and reported by the amber flashing LED when the alarm is unset
- 1 flash = 1st to alarm, 2 flashes = 2nd to alarm and so on up to the 10th unit to alarm.
Any units that did not alarm will show a green flashing LED.
- To reset the alarm memory, apply the "set" input signal for 3 seconds and then remove. Otherwise the trapper(s) will reset the next time that the system is set.

Confidence Mode

- Remove the link "Q" and fit to one pin only as in Fig. 15.

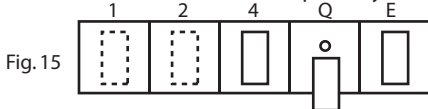

- The green LED will flash at 2Hz until either,
 - An alarm condition (red LED for 3 seconds) or,
 - Smaller shock(s) are stored in the pulse count memory (every 5th green flash will miss, as in Fig. 16).

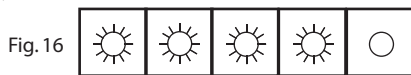

Quiet Modes

- Fitting link "Q" will disable the green flashing LED as in Fig. 17

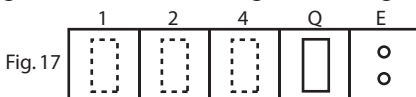

- Linking the +12V input to the "set" input will disable all LED functions as in Fig 18.

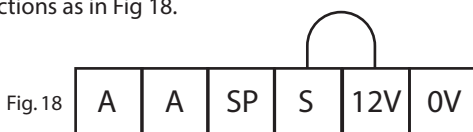

Only use in conjunction with Intruder Alarm Systems.

Environmental Advice.

This product is covered by current WEEE regulations. Please consider the effect on the environment when disposing of it. Do not put in a domestic waste bin. Only dispose of at an appointed recycling centre.

RoHS compliant.



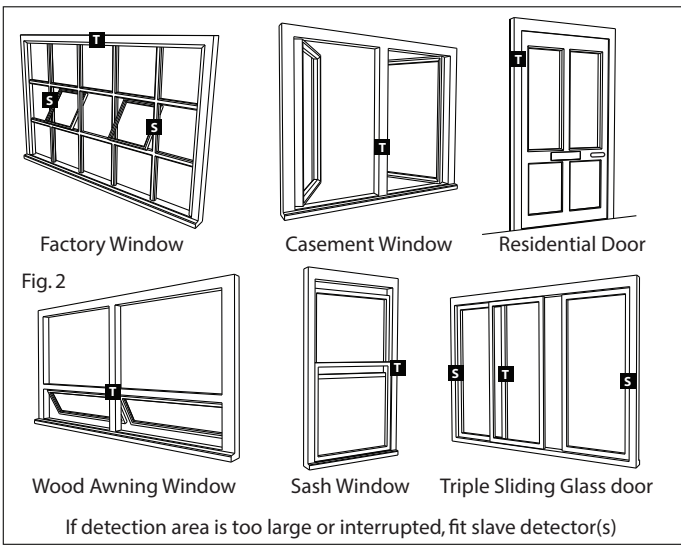

The Shock Sensor module is to be placed into the base moulding as seen in Fig. 3

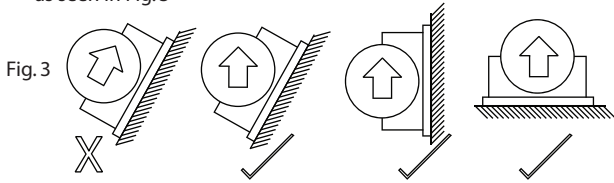

Ensure arrow on the module points vertically upwards

This can be done by turning the cradle through 90°. This adjustment allows horizontal or vertical mounting through 360°

Wiring

Using a standard alarm cable of either 6 cores (std operation) or 8 cores (latch operation), make the connections to the host control panel and slave sensor(s) and/or contacts if used.

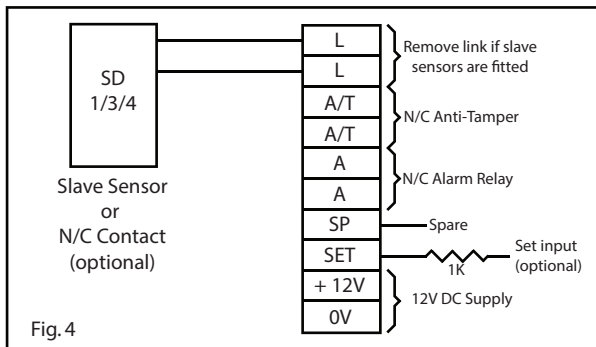

Setting the Sensitivity

The detection sensitivity may be set either automatically, whereby the Trapper will indicate the required setting once a test shock is applied to the protected surface, or manually referring to the amber shock strength LED as an indicator.

Automatic Sensitivity Control

1. Apply power and remove links (LK1, 2, 4 and Q) as in Fig. 5

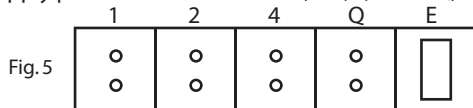

2. Remove and the refit link "E" to reset memory.
3. Firmly strike the protected area at a point furthest from the detector, using a hard object or suitable calibration tool, as in Fig. 6.

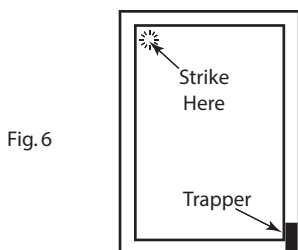

2

4. The shock signals received by the Trapper will be remembered as 80% of an alarm signal.

5. The LED will flash red a number of times. *

Count the flashes and select the shock level by fitting the links, as in Fig. 7

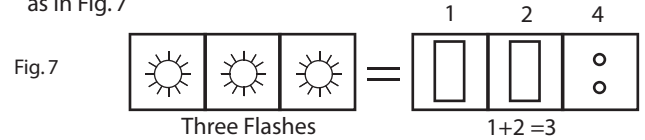

The table in Fig. 8 below shows link positions

Flashes	LK1	LK2	LK4	
1	On	Off	Off	Maximum
2	Off	On	Off	
3	On	On	Off	
4	Off	Off	On	
5	On	Off	On	
6	Off	On	On	
7	On	On	On	Minimum

6. Repeat steps 1 to 5

7. Remove Link "E"; the detection level is now set.

The green LED will flash at 2 Hz

If the LED does not flash, the trapper has not received a shock signal. This may be because:

- The test shock was too small, or
- The detection area is too large.

* To correct either:

- Increase the test shock or
- Fit additional slave sensor(s) to increase detection area.

If the detection area is too large or interrupted, fit slave detector(s) as shown in Fig. 9

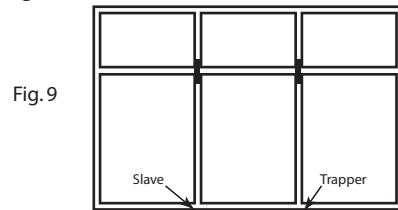

Testing the level of Detection

1. Set the required detection level, by fitting the sensitivity links.

2. Fit the link "E" as in Fig. 10.

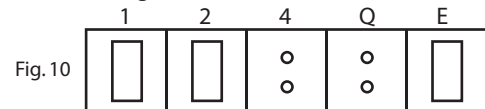

3. Strike the protected surface.

4. After 3 seconds the LED will flash amber to indicate level of shock received.

1 flash = 20% of an alarm, 2 flashes = 40%,
3 flashes = 60% as in Fig. 10a, 4 flashes = 80%, red = alarm.

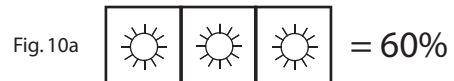

5. The amber LED will continue to flash (with short pauses) to show the memory status.

6. As more small shocks are applied, the LED will show the accumulated level of shock held in the pulse count memory.

7. Repeat steps 2 to 4 throughout the protected area, to assess the level of detection achieved.

Remove link "E" when detection testes are complete.

Note: The pulse count memory may be cleared by causing the Trapper to go into alarm (Red LED).

Manual Sensitivity Control

1. Fit Link "E" and the three sensitivity links as required as in Fig. 11.

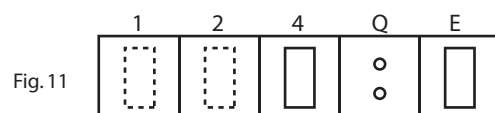

3