

Hybrid Receiver (HR-7(-F1) / HR-8(-F1)/ HRA-8)

The Hybrid Receiver receives signals from learned-in wireless sensors, and activates the Alarm / Fault / Tamper outputs based on function switch settings.

● IDENTIFYING THE PARTS

Front View

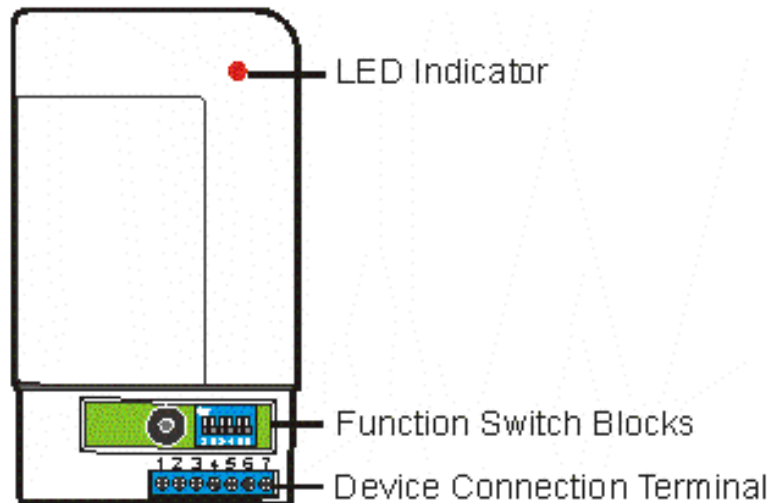

Side View

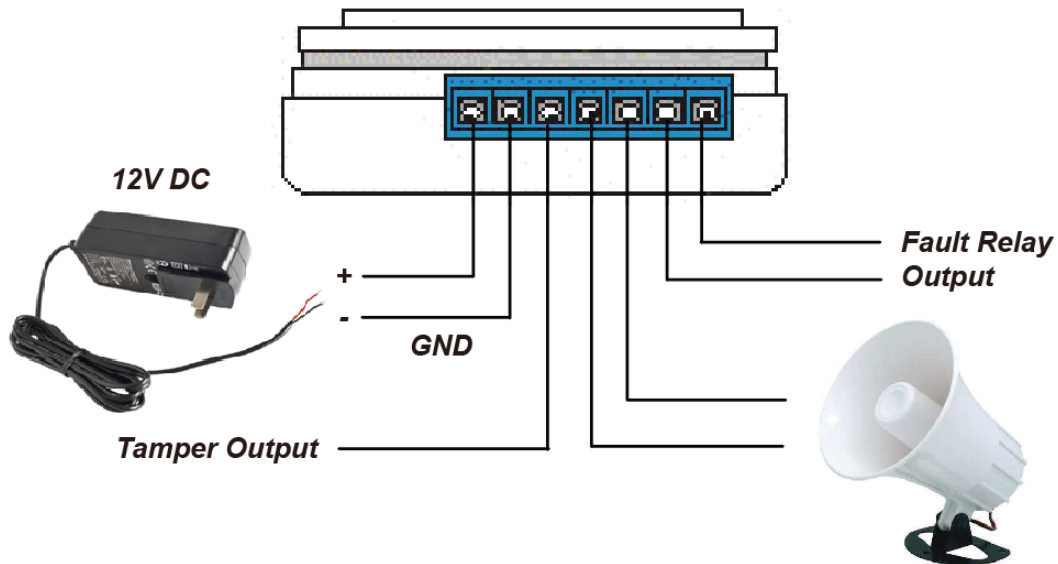

■ Pin 1 & 2 provide constant DC 12V Input

- Pin 1 is (+) polarity
- Pin 2 is (-) polarity, Ground

■ Pin 3 provides DC 12V tamper output

- This is for you to connect a wired device, which will activate once HR receives tamper signal from the learnt-in sensors.

☞ **SW3** must be set to **ON** to include tamper as Fault output.

■ **Pin 4 & 5 provides an “alarm” relay output**

- This is for you to connect a wired device, which will activate once HR receives alarm signal from the learnt-in sensors.
- Based on (SW4) setting, the alarm relay output can form a Normally Closed (N.C.) or Normally Open (N.O.) loop with the connected device. Please refer to the (SW4) section for more information.

■ **Pin 6 & 7 provides a “fault” relay output**

- This is for you to connect a wired device, which will activate once HR receives fault signal from the learnt-in sensors.
- The fault relay output always forms a Normally Closed (N.C.) loop with the connected device.
- The fault signals include:
 - Low Battery
 - Supervision Failure over 4 hours
(SW2 must be set to **ON** to enable Supervision function)
 - Tamper Open
(SW3 must be set to **ON** to include tamper as Fault output.)

● **FUNCTION SWITCH BLOCK**

Open the protective cover; notice the switch block set consisting of 6 DIP Switches marked (1-6) left to right. DIP Switch **Top** location indicates the (**ON**) position. **Bottom** location indicates the (**OFF**) position.

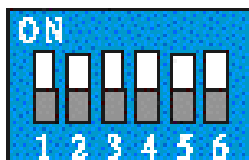

● (SW1) Learn-in mode programming options:

- ◆ In learning mode, LED indicator will flash every second.
- ◆ If the RF signal is received, one long beep indicates the device has been previously learned-in.

☞ Please refer to section “Learn-in device” below to find more information.

● (SW2) is used to enable/disable Supervision function:

- ◆ When supervision function is enabled by setting SW2 to ON, any lack (over 4 hrs) of sensor (IR/SD/DC/WS) response will activate PIN 6 & 7 (fault relay output) from the HR.

● (SW3) is used to include / exclude Tamper as Fault output.

- ◆ When SW3 is set to “ON”:

SW1	Learning Device
ON	Learning Mode
OFF	Normal Operation
SW2	Supervision
ON	Enable
OFF	Disable
SW3	Tamper Fault Output
ON	Tamper included
OFF	Tamper excluded
SW4	Relay Operation
ON	Normal Close
OFF	Normal Open
SW5	Relay Operation
ON	Latch
OFF	Pulse
SW6	Test mode / Clear LED Fault Display
ON	In Test Mode
OFF	In Normal Mode

- **PIN 3 (DC 12V tamper output)** will export 12V to connected device once tamper signal is received from the learnt-in sensors. After Tamper condition is restored, PIN 3 output returns to 0V.
 - **PIN 6 & 7 (fault relay output)** will activate connected device when tamper signal is received from the learnt-in sensors.
 - ◆ When SW3 is set to “OFF”:
 - **PIN 3 (DC 12V tamper output)** will always stays at 0V whenever tamper signal is received from the learnt-in sensors.
 - **PIN 6 & 7 (fault relay output)** will **NOT** activate connected device when tamper signal is received from the learnt-in sensors.
- **(SW4) is used to program Normal Open / Normal Close for Alarm Relay.**
 - ◆ This Switch is used to program NO / NC for Alarm relay.
 - ◆ When SW4 is set to “ON” position (**Normal Close**), the loop is opened when alarm signal is received.
 - ◆ When SW4 is set to “OFF” position (**Normal Open**), the loop is closed when alarm signal is received.

☞ Only the Alarm Relay can be switched to NO / NC by adjusting SW4 setting. Fault Relay is always in Normal Close state.
 - **(SW5) is used to program Output Type for Fault / Alarm Relay.**
 - ◆ **LATCH** –Once **Pin 4 & 5 (alarm relay output)** or **PIN 6 & 7 (fault relay output)** activates, it will continue to activate until all fault(s) or alarm(s) are restored.

Alarm & Fault examples are as below.

Alarm Relay Output	Fault Relay Output
<p>Door Contact (DC): Open → <u>Output activate</u> Close → <u>Output restore</u></p> <p>Smoke Detector (SD): Trigger → <u>Output activate</u> Test button pressed when alarm / When smoke concentration is lower than the set value for 3 min or more (auto restore) → <u>Output restore</u></p> <p>Wrist Transmitter (WTR) /Panic Button (PB): Button pressed → <u>Output activate</u> Button pressed and held for 7 sec → <u>Output restore</u></p> <p>Water Sensor (WS) Water detected → <u>Output activate</u> Dry → <u>Output restore</u></p> <p>Remote Control (RC): Arm/Panic/Home button pressed → <u>Output activate</u>; Disarm button pressed → <u>Output restore</u></p>	<p>Low Battery Battery Voltage Low → <u>Output activate</u> Battery Voltage restores to Normal → <u>Output restore</u></p> <p>Supervision Failure Sensor supervision fails for 4 hours → <u>Output activate</u> Sensor supervision restores → <u>Output restore</u> (SW2 must be set to ON to enable Supervision function)</p> <p>Tamper Open Sensor’s tamper triggered → <u>Output activate</u> Sensor’s tamper restored → <u>Output restore</u> (SW3 must be set to ON to include tamper as Fault output.)</p>

- ◆ **PULSE** – Any **alarm relay output** or **fault relay output** activation will result in a 3-second pulse.

<NOTE>

- ☞ If the alarm signal comes from an **IR sensor**, the relay activates as **pulse** only.

- **(SW6) is used to enter / exit Test mode or clear LED fault display**

- ◆ Set the SW6 to ON to enter Test mode.
- ◆ In Test Mode, the LED flashes every 2 seconds. The HR will beep for 2 seconds after receiving sensor signal.
- ◆ SW6 can also be used to stop LED flash caused by Fault detection. Switch SW6 from “On” to “Off” to stop flash.
Note: this operation only clears LED, not the fault.

- **LEARN-IN DEVICES**

The HR can learn up to **10 devices**. Available devices include PIR sensor (IR), Smoke Detector (SD), Door Contact (DC), Water Sensor (WS) and Panic Button (PB), Wrist Transmitter (WTR), and Remote Control (RC).

Follow the steps below to proceed:

Step 1: Supply 12V DC power to PIN 1&2.

- ◆ LED will turn steady on, then HR will emit a 1-second beep.
- ◆ LED stays on while the HR is in normal mode.

Step 2: Enter Learn-in Mode using a sharp object to slide SW1 up to (**ON**) position.

- ◆ LED flashes rapidly once per second.

Step 3: Press test/learn Button on the device.

- ◆ HR emits a short beep after sensor is learned-in.
- ◆ A long beep sounds indicating the device has been previously learned-in.

Step 4: Repeat from step 3 to learn-in additional devices.

Step 5: Return to Normal Mode using a sharp object to slide SW1 down to the “**OFF**” position.

- ◆ LED stays on after return to normal operation mode.

<NOTE>

- ☞ If 10 total devices have been added, the HR will continue beeping a warning sound until the SW1 is switched to “**OFF**”.
- ☞ Only one device can be learned-in at a time (this prevents faulty signaling).

- **TEST MODE**

After all devices have been learnt-in, you can use Test mode to find a suitable location for installing.

Step 1: Enter Test Mode using a sharp object to slide SW6 up to “**ON**” position. The LED flashes every 2 seconds.

Step 2: Hold the learnt-in device to desired location. Press the test/learn button on the device. HR will emit a 2-second beep after receiving sensor signal.

Step 3: Repeat step 2 to do more test.

Step 4: Sliding the SW6 to “**OFF**” position to return to normal mode.

● NORMAL OPERATION

- LED stays on indicating normal operation.
- When any of alarm signals is received from the learnt-in device, the alarm relay (PIN 4&5) will activate based on SW5 setting (Pulse or Latch), then return to the normal operation mode.
- When low battery signal is received from the learnt-in device, the fault relay (PIN 6&7) will activate c then return to the normal operation mode.
- The PIR sensor, Smoke Detector, Door Contact and Water Sensor will send supervised-signal to the HR at interval between 20~60 min (random). When any supervised-signal lacks (over 4 hrs) and (SW2) is set to ON (Supervision enabled), HR will activate fault relay output (PIN 6&7) based on SW5 setting (Pulse or Latch).
- When the tamper of PIR sensor or Door Contact is triggered and (SW3) is set to ON (Tamper included), HR will activate PIN 3 (DC 12V tamper output) to export 12V to connected device, and activate PIN 6 & 7 (fault relay output) based on SW5 setting (Pulse or Latch).
- LED indicator flashes in different methods for different fault condition:
 - Low Battery : 1 quick flash
 - Tamper : 2 quick flashes
 - Supervision : 3 quick flashes

<NOTE>

- ☞ To display more than 1 status, the LED will display each code at intervals of 1 sec.
- ☞ To clear LED fault display, slide SW6 to “ON”, then back to “OFF” position.
- When HR receives test code from IR/SD/DC/WS, it will emit a beeps and flashes LED once.

● CLEAR DEVICE

This function is used to clear all sensor learnt-in memory.

- ☞ After this procedure is completed, all devices are required to re-learn before they can operate again.

Step 1: Remove HR power supply.

Step 2: Slide all switches up to “ON” position.

Step 3: Reconnect HR power supply.

Step 4: LED will turn steady on.

Step 5: Slide all switches back down to “OFF” position, the HR returns to Normal Operation Mode with 1 second Beep and LED stays on indicating successful clearance.