

# WMU 842

## CHAIN ACTUATOR

### OPENING STROKE SIZES

750 or 1000 mm (programmable)

### PUSH FORCE

400 N

### VOLTAGE

24V DC (+/- 10%)



### DESCRIPTION

The actuator is an extremely strong chain actuator especially developed for large and heavy roof openings and windows in the facades. An elegant alternative to traditional spindle actuators. For comfort ventilation. For smoke ventilation when the actuator opens the window completely within 60sec. (opening time) – approved according to EN 12101-2 with selected profiles. To be used together with  $\pm 24V$  control units or control units with MotorLink®. Can be used together with espagnolette WMB. Synchronization of up to 4 window actuators – no need for an external synchronization module. Genuine position feedback and 3 speeds when using control unit with MotorLink®. Soft close function. The electronics in this actuator can be programmed to suit specific requirements – i.e. pressure- and traction force, stroke, speed/sound level – with the WAT 100 programming box, this is also possible following installation. Built-in electronic load switch-off/end stop. Electronic actuator with micro controller. The actuator has an integrated reverse function to ensure a prolonged life span of the window gaskets. Easy mounting.

### WINDOW TYPES

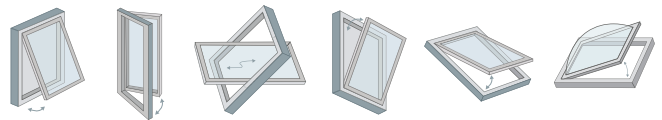

### APPLICATION



COMFORT  
VENTILATION

### COLOURS

- Silver Anodised
- ⊗ Custom RAL colour

## TECHNICAL DATA

Voltage	24V DC (+/- 10%)
Push Force	400 N
Pull Force	500 N
Locking Force	3000 N
Opening Stroke	750 or 1000 mm (programmable)
Opening Speed	12.5mm/s
Current Consumption	2.0 A
Operating Conditions	-15°C - +74 °C max. 90% relative humidity (not condensing)
Switch-on Duration	ED 20% (max. 4min. per 20min.)
Colour	Silver Anodised or custom RAL colour
IP Rating	IP 54
Life Span	10,000 opening and closing movements
Delivery Includes	1 x Actuator (fixing brackets sold separately)
Flex Length	5 m
Cable Dimensions	2-Core (plus 1 communication wire)
Min. window width	> 1007 mm (750 mm stroke) or 1247 mm ( 1000 mm stroke)
Max. window width	< 1300 mm (use multiple actuators if wider)
Synchronisation	Yes (programmable)

## ACCESSORIES

- WAB836E - Vent Bracket
- WAB836H - XL Pivot Bracket

## PART CODES

- WMU8421000-1 - WMU 842-1 Actuator 24 V 1000 mm 400 N 2 A Silver
- WMU8421000-2 - WMU 842-2 Actuator (synchronised) 24 V 1000 mm 400 N 2 A Silver
- WMU842750-1 - WMU 842-1 Actuator 24 V 750 mm 400 N 2 A Silver
- WMU842750-2 - WMU 842-2 Actuator (synchronised) 24 V 750 mm 400 N 2 A Silver

## DIMENSIONS

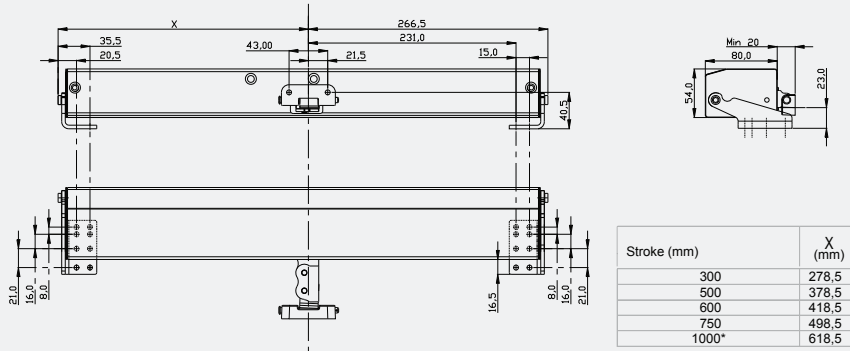

## CONTROLS



**WSC 204**  
AOV Control Unit



**WSK 320**  
Override Switch



**WUC 102**  
Control Unit



**WSK 100**  
Ventilation Keypad

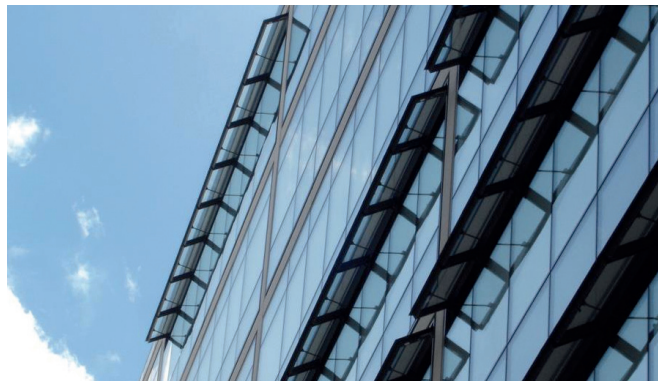
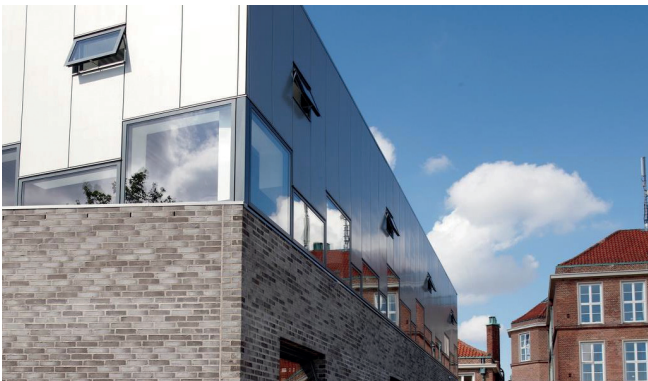

## INSTALLATION EXAMPLES

Rooflight

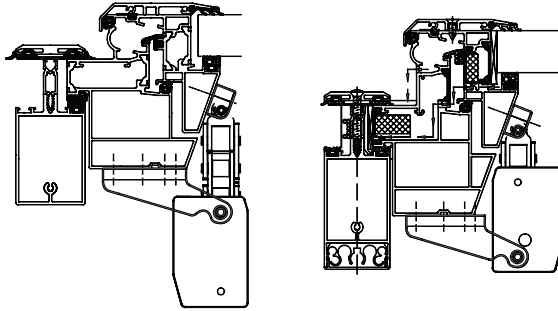

WAB 836E

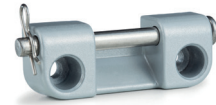

WAB 836H



## ACTUATOR VARIANTS

The actuator is available in four different versions: single actuator (-1), double actuator (-2), triple actuator (-3) and quad actuator (-4). The synchro actuators (-2, -3 and -4) are equipped with a patented synchronization function, in which the actuators communicate directly with each other, which ensures the actuators operate at exactly the same speed and position. On large windows up to four actuators can be mounted on the same window – with no need for an external synchronization module.

## PRESSURE SAFETY FUNCTION

The risk of entrapment is reduced as the actuators are programmed to reverse if they encounter obstacles when closing. The set points determining when the actuators are to reverse are individually adjustable and can be adjusted after installation using the programming box WAT 100.