

Wall Mount

DH-PFB731W

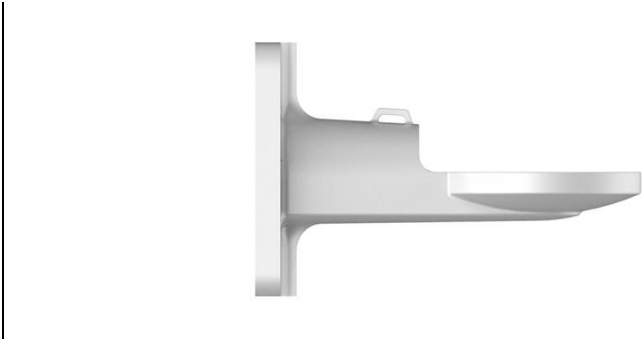

Technical Specification

Model	DH-PFB731W
Wall Mount	
Material	Metal with anti-corrosion coat
Dimension	φ374.5mm*188mm*161mm
Package Dimension	465mm*237mm*275mm
Net Weight	2.12kg(4.67lb)
Load Bearing	30kg(66.14lb)
Operating Conditions	-40°C ~ 60°C (-40°F ~ +140°F) / Less than 95% RH

external size:

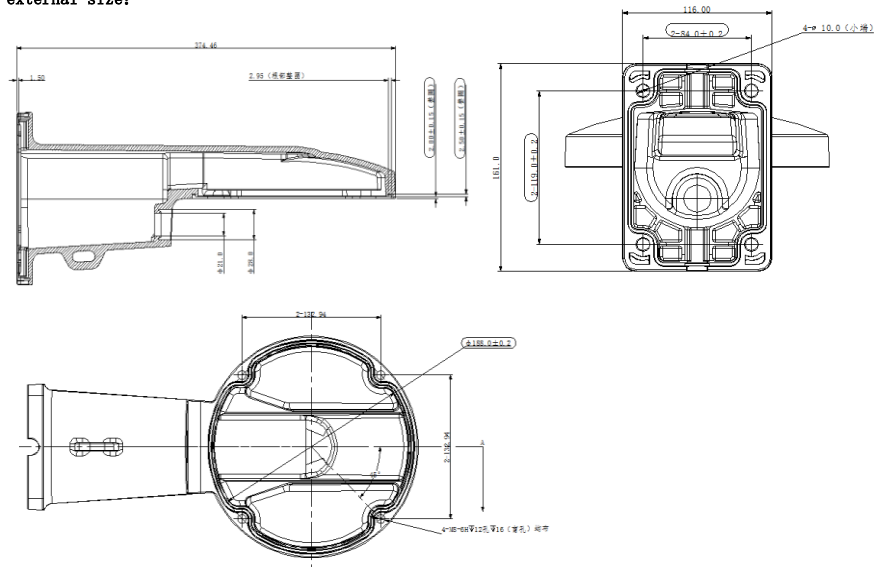

recommend matching accessory:

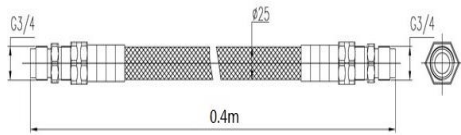

0.4m anti-corrosion
dobbin: 1. 2. 01. 14. 10121



钢丝绳
steel cable, standard equipped
in DH-PTZ19240V-IRB-N