

Safety instructions

① **Note:** The reference to PGPx986 throughout this document includes the models PGP9986 and PGP8986.

The PGPx986 shall be installed and used within an environment that provides the pollution degree max 2 and over voltages category II in non-hazardous locations, indoor only. The equipment is designed to be installed by SERVICE PERSONS only; (SERVICE PERSON is defined as a person having the appropriate technical training and experience necessary to be aware of hazards to which that person may be exposed in performing a task and of measures to minimize the risks to that person or other persons).

The PGPx986 PowerG+ Water Tile with Freeze Detection is powered by two CR2450 batteries, rated 3V.

⚠ **CAUTION:** Only qualified personnel may install this equipment. Place this device in non-hazardous indoor locations only.

➤ **Important:** Check the device and the entire alarm system weekly to ensure optimal performance.

⚠ **WARNING:** This product contains a coin battery. If it is swallowed, it can cause severe internal burns in just 2 hours and can lead to death. Keep new and used batteries away from children. If the battery compartment does not close securely, stop using the product, and keep it away from children. Seek immediate medical attention if you think batteries might have been swallowed or placed inside any part of the body.

Remove and immediately recycle or dispose of used batteries according to local regulations and keep away from children. Do NOT dispose of batteries in household trash or incinerate. Even used batteries may cause severe injury or death. Call a local poison control center for treatment information. Non-rechargeable batteries are not to be recharged.

Do not force discharge, recharge, disassemble, heat above (manufacturer's specified temperature rating) or incinerate. Doing so may result in injury due to venting, leakage or explosion resulting in chemical burns. Ensure the batteries are installed correctly according to polarity (+ and -). Do not mix old and new batteries, different brands or types of batteries, such as alkaline, carbon-zinc, or rechargeable batteries.

Remove and immediately recycle or dispose of batteries from equipment not used for an extended period of time according to local regulations. Always completely secure the battery compartment. If the battery compartment does not close securely, stop using the product, remove the batteries, and keep them away from children.

① **Note:** See D-309611 for installation cut sheet.

About PGPx986 PowerG+ Water Tile with Freeze Detection

The PGPx986 PowerG+ Water Tile with Freeze Detection is a water sensor that alerts homeowners to a leak or flood and is compatible with the IQ Panel 4 and IQ Panel 5. Instructions in this installation guide are based on operation with the IQ Panel 4. The PGPx986 is also compatible with the following panels: IQ4 Hub, IQ4-NS, IQ Pro, IQ5 Hub, IQ5 NS. For device enrollment instructions for each of these panels, refer to the control panel installation guide.

The PGPx986 is also compatible with other PG-enabled panels in legacy/fallback mode. In this mode it will only function as a flood sensor (no freeze detection).

① **Note:** For UL listed applications use the model PGP9986 only in conjunction with the following UL listed control panels: Qolsys Models IQPanel4, IQ4 Hub, IQ4 NS, IQ Panel 5, IQ5 Hub, IQ5 NS that contain the PowerG radio modem card and Tyco/DSC models HS2128, HS2064, HS2032, HS2016 when connected to PowerG transceiver HSM2HOST, keypads with transceiver HS2LCDRF(P)9, HS2ICNRF(P)9 and repeater PG9920.



Introduction

The PGPx986 Water Tile with Freeze Detection includes the following features:

- **Reliable long-range communication:** Features robust two-way PowerG communication with the control panel, utilizing advanced FHSS and TDMA technology for secure and dependable connectivity.
- **Sleek, space-saving design:** The low-profile design allows for discreet installation in various settings without compromising on performance.
- **Enhanced tamper detection:** Offers improved detection for cover, mount, and probes, alerting users to any improper installation or connections.
- **Clear visual indicators:** Equipped with LED indicators that simplify signal strength assessment, ensuring optimal device placement for maximum effectiveness.
- **Low battery alerts:** Built-in low battery indication provides timely notifications to ensure the device remains operational.
- **Over-the-air firmware updates:** Effortlessly upgrade device firmware remotely, enhancing functionality and security without the need for physical access.

ⓘ Note: Firmware update is not used on UL listed applications.

- **Multifunction button:** A versatile button that facilitates device enrollment, reset, and mute functions, ensuring user-friendly operation.
- **Audible water leak alerts:** Emits a clear audible alert in the event of a water leak, prompting immediate attention.
- **Integrated low temperature alerts:** Low temperature reporting to detect freezing conditions and prevent potential damage.
- **External probe and sensing cable support:** Compatible with external probes and sensing cables (accessories sold separately) to enhance monitoring capabilities.

The PGPx986 Water Tile with Freeze Detection includes the following components:

Figure 1: Device components

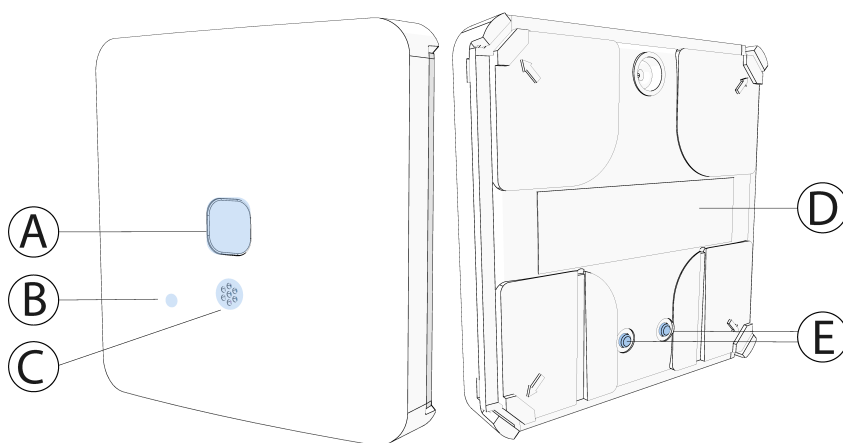

Callout	Description
A	Multifunction button
B	LED
C	Buzzer

Callout	Description
D	Nameplate
E	Electrodes

Optional accessories (ordered separately) are available to enhance the PGPx986 installation, allowing mounting on vertical surfaces (with PGPx986-ACC-Probe), or covering a larger detection area (with PGPx986-ACC-Cable 6ft. or PGPx986-ACC-Cable 12ft.).

Part number	Model name	Description
PGPx986-ACC-Cable 6 ft.	Accessory - wall mount + 6 ft. sensor cable	Accessory kit including wall mount bracket and 6 ft. sensor cable for use with PGPx986
PGPx986-ACC-Cable 12 ft.	Accessory - wall mount + 12 ft. sensor cable	Accessory kit including wall mount bracket and 12 ft. sensor cable for use with PGPx986
PGPx986-ACC-Probe	Accessory - wall mount + sensor probe	Accessory kit including wall mount bracket and external sensor probe for using with PGPx986

Contents of box

- Device
- Manual
- Two-sided tape 13x13 mm

Initially powering up the device or replacing the battery in the device

- ▲ **CAUTION:** Do not replace the battery with an incorrect battery type. See [Specifications](#) for acceptable battery types. Dispose of used batteries according to the manufacturer's instructions and according to local rules and regulations.
- **Important:** The batteries are shipped with reverse polarity, which means they are pre-installed in the device upside down. To power up the device for the first time, reinsert the batteries with the positive (+) symbol facing up.
- ① **Note:** It is recommended to use a flat screwdriver #2.
 1. Carefully insert a flat-head screwdriver to the corner slot shown in the image below (A).
 2. Apply gentle pressure to the screwdriver at an angle to lift open the device's inside cover tabs (B). Be cautious not to apply too much force, because this could break the tabs.
 3. Repeat steps one and two for each corner tab, and then remove the cover (C).

Figure 2: Removing the cover

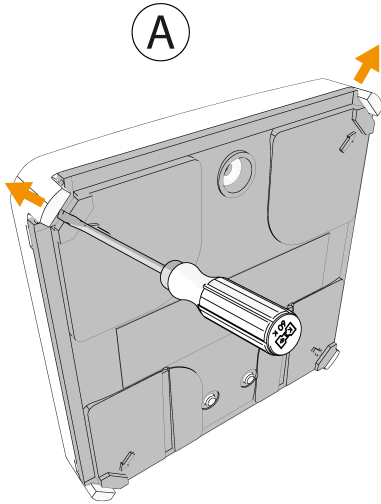

Note: Do not use an electric screwdriver. This causes damage to the plastic enclosure.

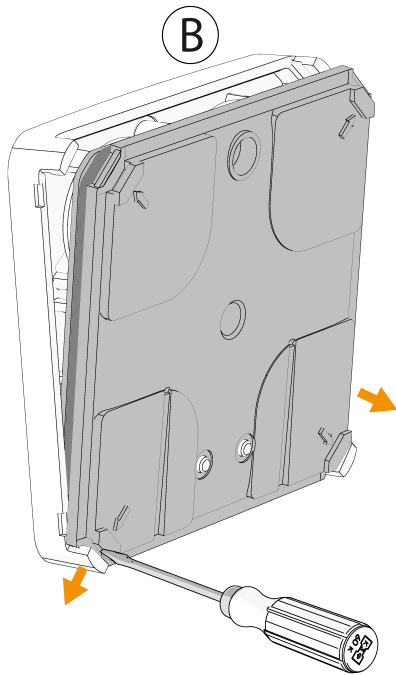

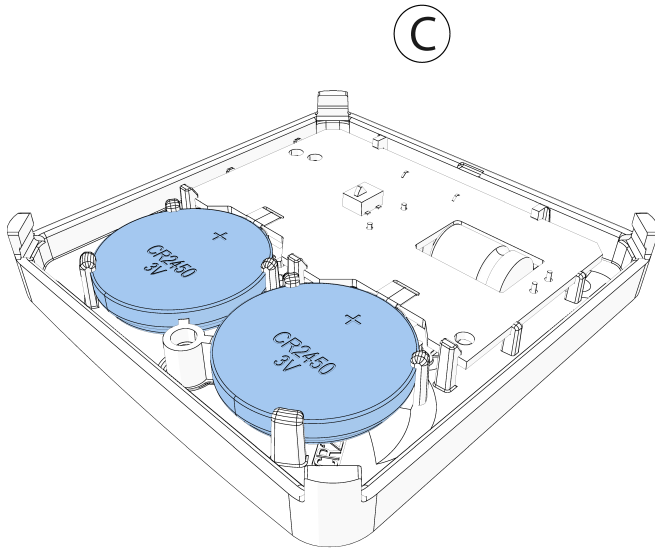

4. Pull the front clasp back and release the battery. See [Figure 3](#).

Figure 3: Removing the battery

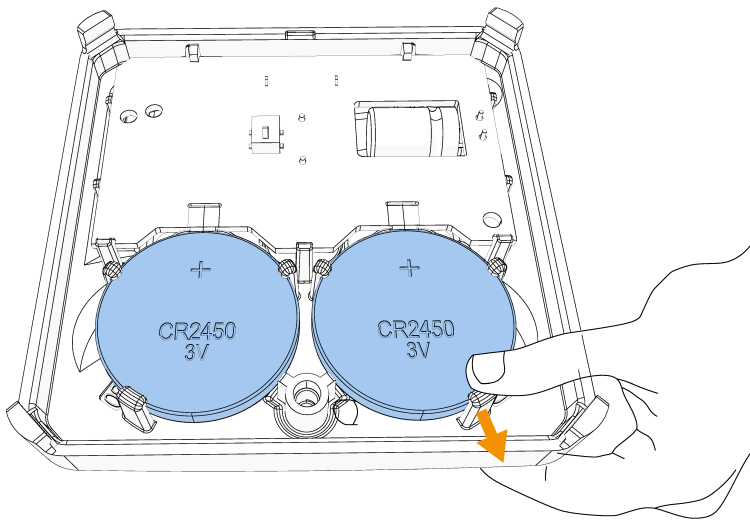

- ⓘ **Note:** Do not use a screwdriver or other metal tool to remove the battery.
5. Insert the new battery at an angle under the two back clasps (A). See [Figure 4](#).
 6. Push the battery down under the front clasp.
- ⓘ **Note:** When you insert the battery, ensure the (+) symbol is visible.

Figure 4: Inserting the new battery

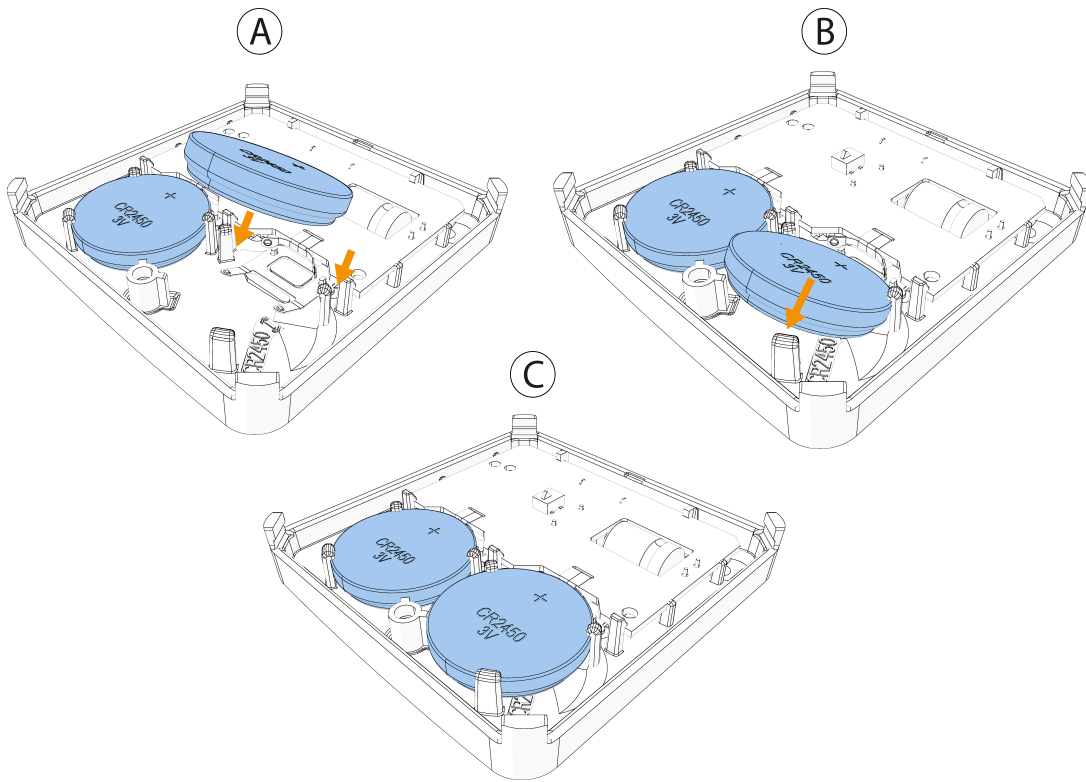

7. Snap the device cover back into place. See the following figure. Do a visual check to ensure the cover is completely closed. After you restore a low battery, the system takes up to 5 minutes to clear the trouble.

Figure 5: Closing the device cover

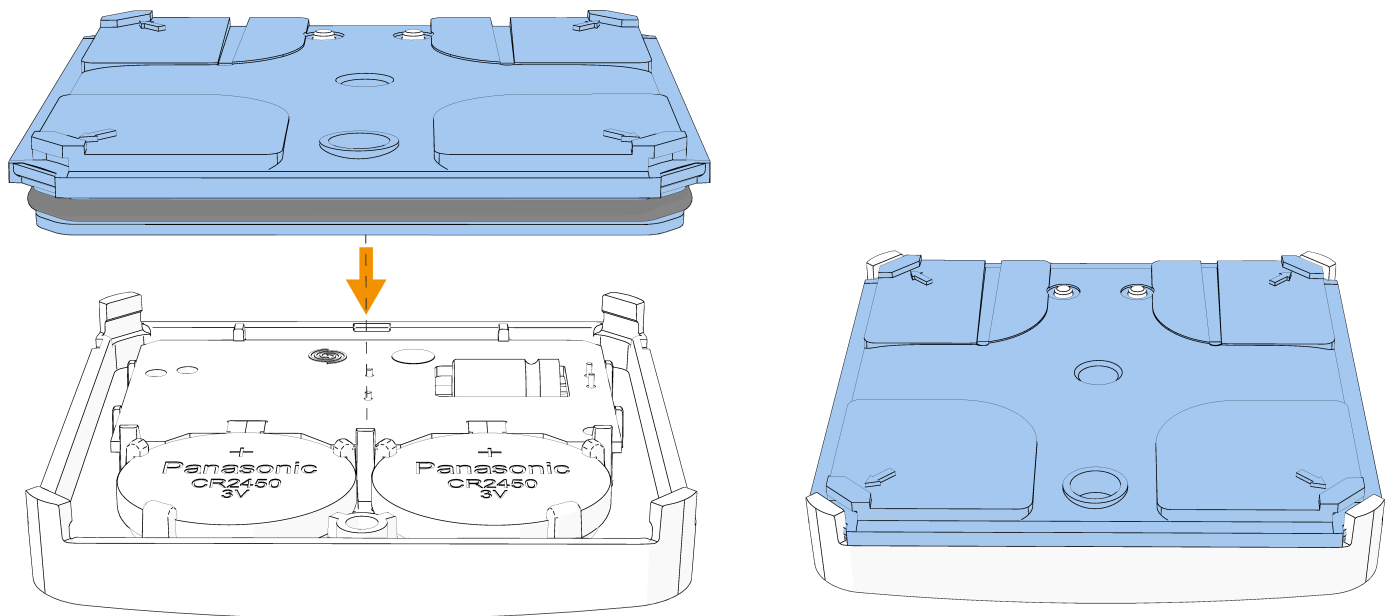

Enrolling the device using Auto Learn Sensor

Enroll the PGPx986 device on your panel with the installation menu. Refer to your control panel installation manual for a complete set of enrollment instructions. The following instructions refer to the IQ4 panel.

Ensure the device is powered up.

1. On the IQ panel menu, select **Settings > Advanced Settings**.
 2. Enter your 4-digit installer code.
 3. Select **Installation > Devices > Security Sensors > Auto Learn Sensor**.
 4. Press the multifunction button for three seconds until the yellow LED turns ON, or insert the batteries.
 5. Release the multifunction button. The LED turns off. The device enters enrollment mode, and the panel is notified of the device initiating enrollment. The PGPx986 is enrolled with device ID 242-XXXX. Use the 7-digit ID on the back of the device to enroll the device to the control panel.
 6. When the device is recognized, select **OK** when the pop-up window appears.
 7. Configure the required device parameters.
 8. **Optional on the IQ4 panel:** Enter the PIN code on the device product label for increased security during enrollment. The device does not pair with the panel if you enter an incorrect PIN code.
 9. Select **Add New**.
 10. Mount (when using with accessories) or fix the device to desired location (water tile only). See [Local diagnostics test](#) for information about testing the device.
- ⓘ **Note:** If the device does not automatically enroll, perform a factory reset as described in [Resetting to factory default settings](#).

Enrolling the device manually or with a QR code

Enroll the device in the IQ panel using the Add Sensor feature or scan the QR code on the box label using IQ4 camera. To enroll the device in the IQ panel using the Add PowerG feature, complete the following steps

1. On the IQ panel menu, select **Settings > Advanced Settings**.
 2. Enter your 4-digit installer code.
 3. Select **Installation > Devices > Security Sensors > Add Sensor** (for manual enrollment) or **Scan QR Code** for QR code enrollment.
 4. Enter the sensor ID in the Sensor ID field or scan the QR code on the box label to enroll the device.
 5. **Optional:** Enter the PIN code on the product label for increased security during enrollment. The device does not pair with the panel if you enter an incorrect PIN code.
 6. Select **Add New**. In a few minutes, the device should automatically enroll. to speed up this process, open the battery cover.
 7. Mount (when using with accessories) or fix the device to desired location (water tile only). See [Local diagnostics test](#) for information about testing the device.
- ⓘ **Note:** If the device does not automatically enroll, perform a factory reset as described in [Resetting to factory default settings](#).

Enrolling the device using Fallback Mode

1. Enroll the device in fallback mode as FLD-550 PG2 with device ID 240-XXXX. For PGP8986-2, enroll the device in fallback mode with device ID 241-XXXX.

Fallback mode is available for the following panels:

- IQ 4 – firmware at 4.5.1
- IQ 2 – firmware at 2.8.1
- IQ Hub – firmware at least 3.1.2
- IQ Pro – firmware at 4.3.0
- Power Series Neo – firmware at 1.37 (EMEA) and firmware at 1.5 (NA)
 - *with PG Keypad built-in transceiver – HS2LCDRFx / HS2LCDRFPx / HS2ICNRFx / HS2ICNRFPx: Firmware at 1.33
 - * with HSM2HOST9: Firmware at 1.33
- PGPHOST9
- Power Series Pro – firmware at 1.4
- PowerMaster-30 G2 – firmware at 18, 19.412 and 20.2
- PowerMaster-360R – firmware at 18, 19.412 and 20.2
- PowerMaster-10 G2 – firmware at 18, 19.412 and 20.2
- Absoluta Plus – firmware at least 4.0

Note that the fallback system has the following limitations:

- No alerts for probe disconnect
- No configuration for the LED
- No configuration for the buzzer
- No alerts for low temperature/ freeze
- No over-the-air update
- No QR code enrollment

Configuring device parameters

If the option is available on your panel, configure device parameters on your control panel when you enroll your device.

See [Table 1](#) for configuration options.

Table 1: Configuration options

Option	Action
Activation LED	Define whether the alarm LED indication will be activated. Optional settings: Enable (default) and Disable.
Buzzer	Define whether the alarm buzzer sound will be audible. Optional settings: Enable (default) and Disable.
External tamper	Define the settings for external tamper alerts. Note that internal tamper alerts are always enabled. <ul style="list-style-type: none"> • Disabled: No external tamper alerts. • Wall and Probe: External alerts are sent for both wall tamper and probe tamper events.

Local diagnostics test

After you power up or close the cover on the device, it automatically enters test mode for 15 minutes.

❗ **Note:** To manually enter devices into test mode, refer to your control panel installation guide.

1. Before you start the test, remove the device cover from the base. See [Figure 2](#).
2. Close the cover to return the tamper switch to its normal position. The red LED blinks.
3. Wait for a few seconds until the red LED stops blinking.
4. Test the flood function. See [Testing the flood function](#).

Table 2: Signal strength indication

LED Response	Reception
Green LED blinks	Strong
Yellow LED blinks	Good
Red LED blinks	Poor
No blink	No communication

- **Important:** Ensure you have reliable reception. Poor signal strength is not acceptable. If you receive poor signal from the device, relocate it and re-test until you get good or strong signal strength. Verify the signal strength with the control panel diagnostic test. For detailed diagnostics test instructions, refer to the control panel installation guide for your control panel. For UL/ULC installations, only strong signal levels are acceptable.

Checking the signal strength

1. On the IQ4 panel, select **Settings > Advanced**.
2. Enter the installer code.
3. Select **System tests > PowerG Test**.
4. Check the signal strength according to the LED. See the following table for details,

Table 3: Signal strength indication

LED response	Reception
Green LED blinks	Strong
Orange LED blinks	Good
Red LED blinks	Poor
No blinks	No communication

Testing the flood function

For the internal sensor or sensor probe, the water should make contact with both sensors. For the sensing cable, the water should make contact with any portion of the cable.

1. Choose option a or b.
 - a. For the internal sensor, place the device in a small container. Make sure it is stable.
 - b. For extension probe or sensing cable, place the sensing probe or the sensing cable in a small container. Make sure it is stable. Please make sure the sensor probe or sensor cable is connected properly with the wall mount and device before the test starts.
2. Slowly run water into the container until it reaches the extension probe or sensing cable. Monitor the water level to ensure it makes contact with the sensor. Wait for the water tile to trigger the alarm on the control panel.
3. Once the alarm on the control panel is activated, carefully remove the immersed portion of the water tile from the container.
4. Gently wipe off any excess water to remove moisture.
5. Dry the parts thoroughly. Use a soft, dry towel to wipe down the device, and extension probe or sensing cables.
6. Allow the device, and extension probe or sensing cables to air dry completely. After the device, and extension probe or sensing cables are completely dry, carefully place it back in its designated location.

Testing the freeze detection function

If the freeze feature is available, perform the following steps to test the freeze detection function.

1. Place the water tile in a dry area of the freezer.
2. Wait for the temperature reading of the water tile to drop below 5 °C (41 °F) for low temperature to trigger the freeze alarm on the control panel.
3. Once the alarm on the control panel is activated, carefully remove the sensor from the freezer.
4. Gently wipe off any excess water to prevent moisture from lingering.
5. Dry the sensor thoroughly. Use a soft, dry towel to wipe down the sensor. Ensure all surfaces, including connectors and openings, are free from moisture.
6. Allow the sensor to air dry completely. After the sensor is completely dry, carefully place it back in its designated location.

Mounting the device

- Do not install near high-voltage electrical lines.
 - Do not install outdoors.
 - Place the device on the floor or mount it on the wall with a bracket at any height. Ensure the device is in the correct location, ideally near potential flood sources.
- ⓘ **Note:** The bracket is not intended to be submerged in water.
- ⚠ **CAUTION:** The included double-sided tape may damage your flooring finish. Johnson Controls will not be held liable for any damages incurred. If you choose to use the double-sided tape for mounting the device, we strongly recommend consulting your flooring manufacturer for appropriate adhesive options.
- **Important:** Insert the batteries before mounting the device. See [Initially powering up the device or replacing the battery in the device](#).

Using the optional double-sided tape

1. Peel the release liners off the two adhesive tape pads.
2. Attach the two tape pads to the back of the device.

Figure 6: Optional: Attaching Tape

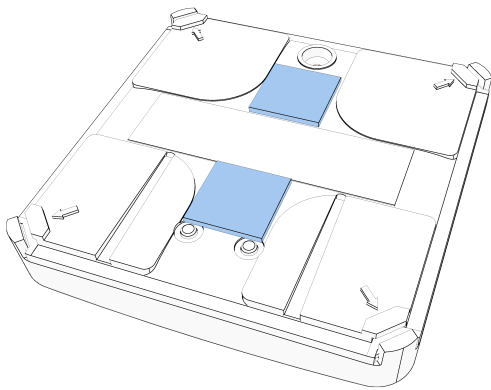

- ⚠ **CAUTION:** Do not cover the electrodes.
3. Attach the device to the floor, in an area that is likely to experience flooding.
 4. Hold the device in place for one minute to ensure it is attached.

Figure 7: Attaching to the floor

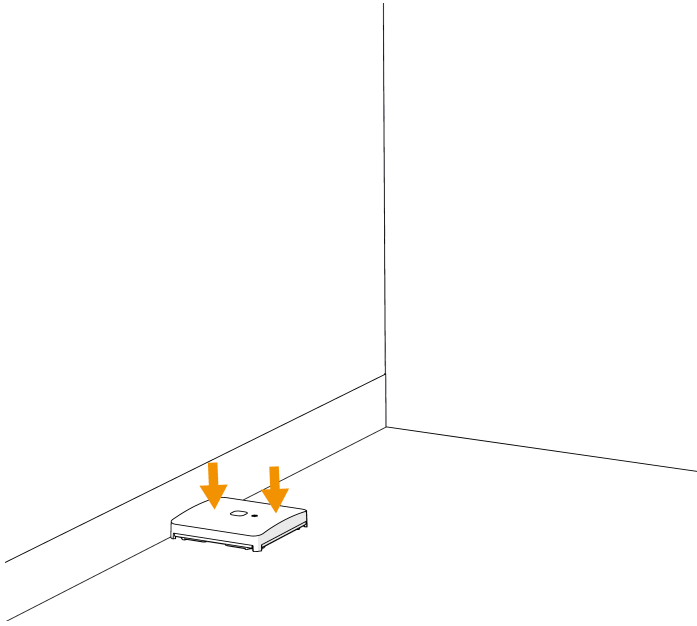

Optional: Mounting the device with a PGPx986-ACC-Cable

Perform the following steps to mount the device with a sensing cable.

1. Connect the sensing cable to the bracket.

Figure 8: Connecting the cable to the bracket

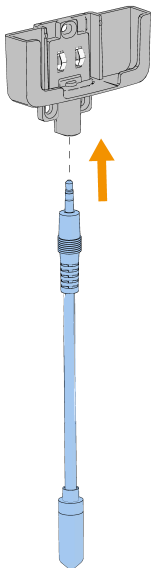

2. Lie the sensing cable on the floor.

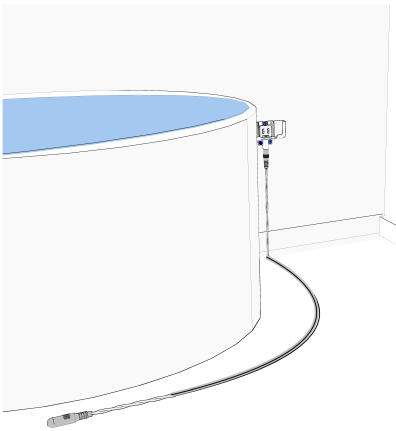
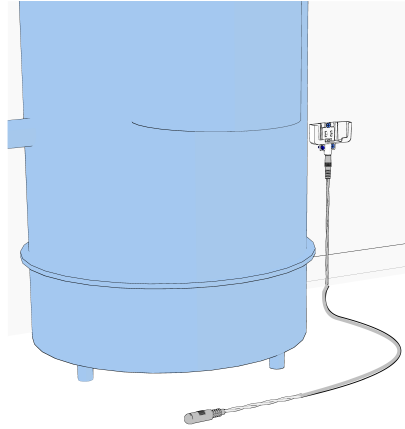
Figure 9: Lie the sensing cable on the floor

3. **Optional:** Use the supplied clips to fix the cable to the floor or surface. Keep approximately 40 cm (16 in.) distance between each clip.
4. Attach the bracket to the wall with three screws. Recommended screw size is Philips #6 x 1 in. long. Do not use electrical screwdriver.
 - ⓘ **Note:** When choosing a mounting location, ensure there is sufficient height left below the bracket for the connector of sensing cable.
 - ⓘ **Note:** For UL-2017 compliance, screws must be installed.

Figure 10: Attach the bracket to the wall

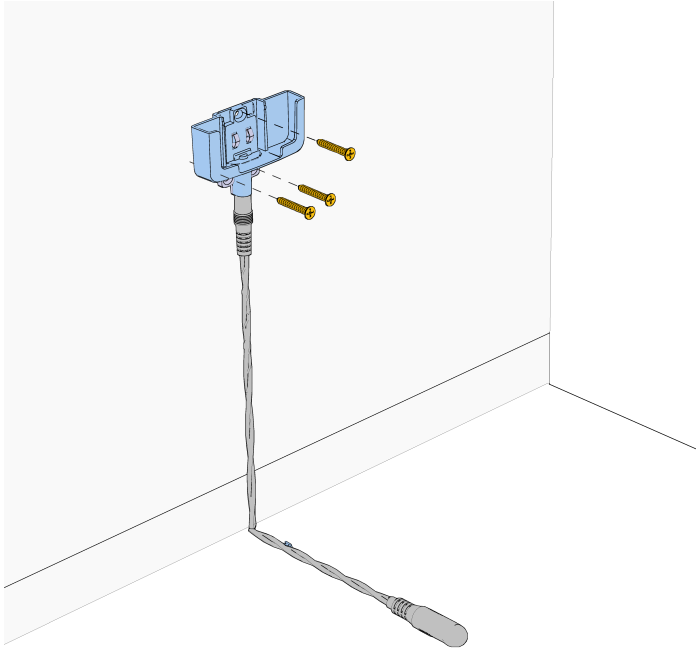

ⓘ **Note:** Use only the screws supplied in the kit.

5. Slide the device into the bracket until it clicks into place.

Figure 11: Inserting the device into the bracket

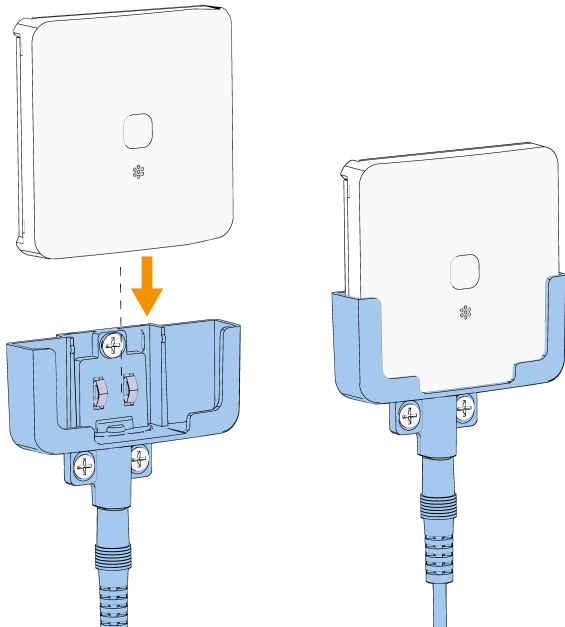

Optional: Mounting the device with a PGPx986-ACC-Probe

Perform the following steps to mount the device with an external probe.

1. Connect the external probe to the bracket.

Figure 12: Connecting the external probe to the bracket

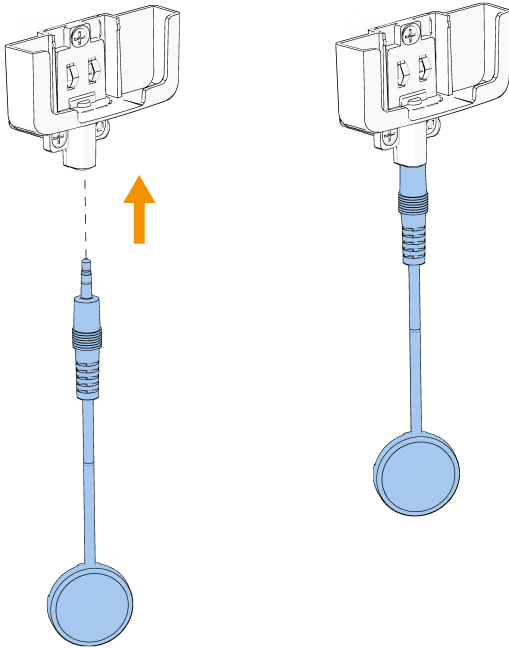

2. To place, lay the external probe on the floor.

Figure 13: Placing the external probe on the floor

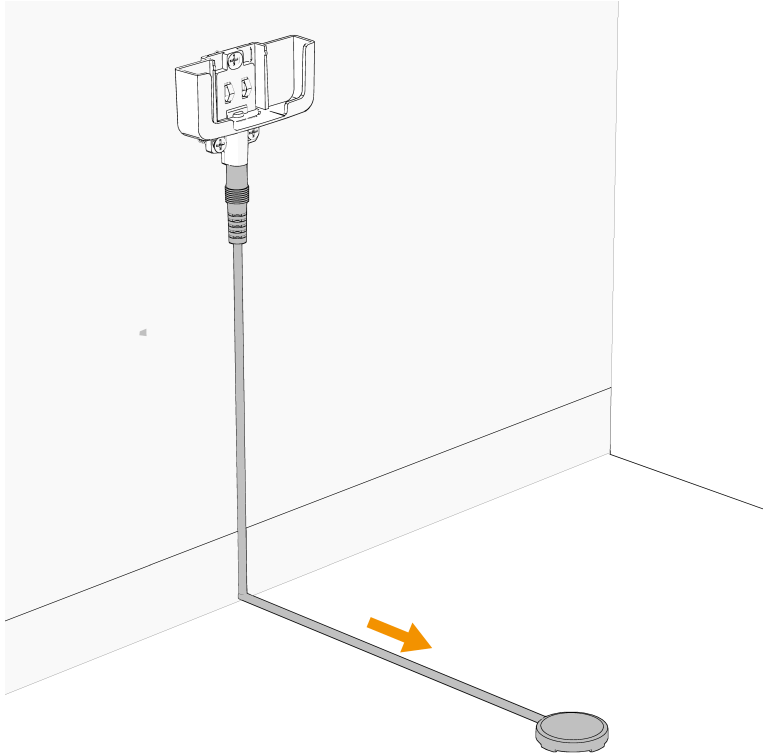

3. Secure with tape.
4. Attach the bracket to the wall with the three screws provided in the kit.
 - ⓘ **Note:** Use only the screws supplied in the mounting kit.
5. Insert the device into the bracket.

Flood alarm events

- The PGPx986 can detect leaks from all water-based liquids, except for distilled water.
- When a flood alarm is triggered, the PGPx986 indicates the event on the control panel, and the device LED blinks red while the buzzer emits an audible beep.
- To silence the PGPx986 buzzer during a flood alarm, press and hold the multifunction button until you hear two beeps. The PGPx986 buzzer remains muted until the device's status returns to normal, then the buzzer reactivates.
- After a flood alarm event, please refer to [Testing the flood function](#) for instructions on how to reset the PGPx986.

Maintenance

To ensure optimum performance, complete the following maintenance tasks periodically.

- Wipe the water tile and its sensors with a soft, dry cloth to remove dust and debris.
- Avoid harsh chemicals when cleaning. Do not use abrasive cleaners or solvents that may damage the device
- After each flood detection, the device, sensing cable, and external probe should be cleaned and dried. Otherwise, the unit may not operate as intended due to the nature of different liquids
- Check the battery levels regularly to ensure the detector remains operational.

Troubleshooting

Problem	Solution
Not powering on	<p>Check battery installation: Ensure that the batteries are installed correctly. Remove the batteries and reinsert them in the correct orientation.</p> <p>Inspect batteries: Check if the batteries are old or depleted, and replace them with new recommended batteries if necessary.</p>
Low battery notification	<p>Promptly replace: Replace the battery as soon as possible to maintain device functionality. Delaying battery replacement could result in loss of detection capabilities.</p>
Connectivity issues to the control panel	<p>Signal strength: If you receive a Low Signal or No Signal alert during panel signal tests, try relocating the water tile to a different position where it may receive a stronger signal.</p> <p>Consider repeaters: If connectivity issues persist, consider using a PowerG or PowerG+ repeater to enhance the signal strength between the water tile and the control panel.</p>
Device does not trigger during an alarm	<p>Placement verification: Ensure the water tile is installed in a suitable location where flooding is likely to occur, avoiding areas with minimal water exposure.</p> <p>Clean sensor, probes and cables: Check that the sensor, and if applicable the probes, or any sensing cables are clean and devoid of debris. Use a soft, dry cloth to wipe them down.</p> <p>Conduct Function Tests: Follow the testing procedures outlined in this user manual to verify water tile functionality.</p> <p>Tampering Test: To test the sensor's responsiveness, remove the battery cover to simulate a tamper condition.</p>
Flood false alarms	<p>Humidity check: Confirm that the water tile is not situated in an excessively humid environment, which could trigger false alarms. If residual humidity or water droplets are present, clean the sensor, probes, and sensing cables, then relocate the sensor to a drier area.</p> <p>Dry sensor and probes: Ensure that the sensor, probes, and sensing cables are completely dry and not in contact with water because this will trigger an alarm. Check probes and cables: inspect if the external probes and/or cables are cut or crushed.</p>
Buzzer does not sound when water is detected	<p>Mute settings: Verify that the buzzer is not set to mute. If it has a mute function, ensure it is disabled.</p> <p>Perform buzzer test: If your control panel has a buzzer test feature, use it to ensure the buzzer is functioning properly.</p>

Problem	Solution
Control panel indicates tamper	<p>Secure battery cover: Ensure that the battery cover on the sensor is properly closed and secured.</p> <p>Check probes and cables: Confirm that the probes and sensing cables are correctly attached and not loose, because this can trigger a tamper alert. Check if the external probes and/or cables are cut or crushed.</p>
Leak alarm triggered after resetting the water tile	<p>Investigate leak cause: The cause of the leak alarm may still be present. Inspect the area for ongoing leaks or sources of water.</p> <p>Check for moisture: Ensure that the sensor, probes, and sensing cables are completely dry. If they are still wet, the alarm will continue to trigger.</p> <p>Inspect for damage: Examine the sensor and its components for any signs of damage. If any part is damaged, it may need to be replaced.</p>
Cannot locate the device	If your control panel has the feature, use TEST LED and TEST BUZZER to locate the device.

Event trouble notification for external sensors connection options

See the following image and table for external sensor connection options.

- **Important:** It is not recommended to connect the external sensor probe to sensor cable. It is not recommended to use the sensor cable from a third party to connect to the wall mount bracket. The connection is considered out of warranty.

Figure 14: External sensor options

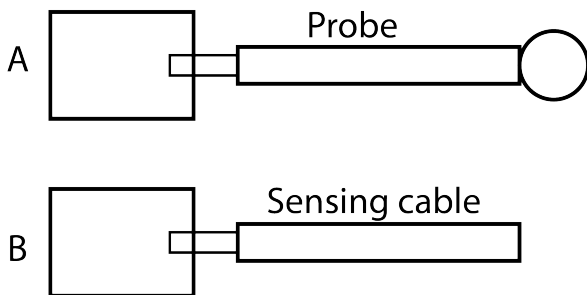

Event	Connection option	
	A	B
	Probe	Sensing cable
Cut	Probe disconnect	
Shorted	Flood alarm	

Resetting to factory default settings

1. Press and hold the multifunction button is pressed for at least 2 seconds until the LED shows a steady orange light.
2. Briefly release the multifunction button, then press and hold the button again for 16 seconds until the LED turns red and flashes three times to indicate a reset to factory default.

Note: After a device is reset back to factory default, delete it from the panel and re-enroll the device.

Specifications

Product specifications for PGPx986 PowerG+ Water Tile with Freeze Detection are outlined in the specifications table.

Table 4: Specifications

Specification	Description
Frequency Band	912 to 919 MHz, 868 to 869 MHz
Maximum Tx power	+14 dBm @ 868 MHz, +18 dBm @ 915MHz
Modulation	GFSK
Communication Protocol	PowerG, PowerG+
Power Supply	Battery
Battery Type	2 X 3V Lithium CR2450 Panasonic, Duracell and GP battery
Battery Life	5 years with typical use at room temperature 77°F (25°C)
Low Battery Threshold	4.3 V at room temperature 77°F (25°C)
Nominal operating voltage	6 V
Current Consumption	Maximum current: 100 mA Minimum current: 0.02 mA
	Quiescent current: 7.5 uA (after a minimum 1 hour of inactivity)
Ingress Protection (IP) rating	IP65
Operating temperature	14°F (-10°C) to 131°F (55°C)
	Note: UL evaluated 32°F (0°C) to 120°F (49°C)
Storage temperature	-4°F (-20°C) to 158°F (70°C)
Relative humidity	Up to 93% non-condensing
Dimensions (LxWxD)	2.6 in. (L) x 2.6 in. (W) x 0.43 in. (H) / 65 mm (L) x 65 mm (W) x 11 mm (H)
Weight (including battery)	1.7oz (48g)
Color	White

Certifications

The PGPx986 PowerG+ Water Tile with Freeze Detection complies with the following standards:

PGP9986	FCC (912 to 919 MHz): 47CFR part 15.247 ISED Canada (912 to 919 MHz): RSS-247 UL/ULC: UL2017 , UL4200A, CSA C22.2 No. 205
PGP8986	EN 62368-1, EN 301489, EN 300220

FCC and ISED Canada Compliance Statement

This device complies with FCC Rules Part 15 and with ISED Canada license-exempt RSS standard(s).

Operation is subject to two conditions:

(1) This device may not cause harmful interference, and (2) this device must accept any interference that may be received or that may cause undesired operation.

Le présent appareil est conforme aux CNR d'ISED Canada applicables aux appareils radio exempts de licence. L'exploitation est autorisée aux deux conditions suivantes:

(1) l'appareil ne doit pas produire de brouillage, et (2) l'utilisateur de l'appareil doit accepter tout brouillage radioélectrique subi, même si le brouillage est susceptible d'en compromettre le fonctionnement.

To comply with FCC Section 1.1310 for human exposure to radio frequency electromagnetic fields and ISED Canada requirements, implement the following instruction:

A distance of at least 20cm. between the equipment and all persons should be maintained during the operation of the equipment.

Le dispositif doit être placé à une distance d'au moins 20 cm à partir de toutes les personnes au cours de son fonctionnement normal. Les antennes utilisées pour ce produit ne doivent pas être situés ou exploités conjointement avec une autre antenne ou transmetteur.

ⓘ Note: This equipment has been tested and found to comply with the limits for a Class B digital device, pursuant to part 15 of the FCC Rules. These limits are designed to provide reasonable protection against harmful interference in a residential installation. This equipment generates, uses and can radiate radio frequency energy and, if not installed and used in accordance with the instructions, may cause harmful interference to radio communications. However, there is no guarantee that interference will not occur in a particular installation. If this equipment does cause harmful interference to radio or television reception, which can be determined by turning the equipment off and on, the user is encouraged to try to correct the interference by one or more of the following measures:

- Reorient or relocate the receiving antenna.
- Increase the separation between the equipment and receiver.
- Connect the equipment into an outlet on a circuit different from that to which the receiver is connected.
- Consult the dealer or an experienced radio/TV technician for help.

This Class B digital apparatus complies with Canadian ICES-003.

Cet appareil numérique de la classe B est conforme à la norme NMB-003 du Canada.

⚠ WARNING: Changes or modifications to this equipment not expressly approved by the party responsible for compliance (DSC.) could void the user's authority to operate the equipment.

Simplified EU declaration of conformity

Hereby, Tyco Safety Products Canada Ltd. Declares that the radio equipment type PGP8986 is in compliance with Directive 2014/53/EU. The full text of the EU declaration of conformity is available at the following internet address: <http://dsc.com/pdf/2501001>



UL/ULC Notes

PGPx986 PowerG+ Water Tile with Freeze Detection is listed by UL/ULC in accordance with the requirements in the Standards UL2017, CSA C22.2. For UL/ULC installations use this device only in conjunction with compatible wireless receivers. After you install the device, verify product functionality in conjunction with the compatible wireless receivers.



WARNING

INGESTION HAZARD

This product contains a button cell or coin battery. DEATH or serious injury can occur if ingested. A swallowed button cell or coin battery can cause Internal Chemical Burns in as little as **2 hours**. KEEP new and used batteries OUT OF REACH of CHILDREN. Seek immediate medical attention if a battery is suspected to be swallowed or inserted inside any part of the body.



WEEE product recycling declaration

WEEE Product recycling declaration



For information regarding the recycling of this product you must contact the company from which you originally purchased it. If you are discarding this product and not returning it for repair then you must ensure that it is returned as identified by your supplier. This product is not to be thrown away with everyday waste. Directive 2012/19/EU Waste Electrical and Electronic Equipment.

Limited warranty

Digital Security Controls (“DSC”), a division of Tyco Safety Products Canada Ltd, a part of the Johnson Controls group of companies (“JCI”), warrants that for a period of 12 months from the date of purchase, the product shall be free of defects in materials and workmanship under normal use and that in fulfillment of any breach of such warranty, JCI shall, at its option, repair or replace the defective equipment upon return of the equipment to its repair depot. This warranty applies only to defects in parts and workmanship and not to damage incurred in shipping or handling, or damage due to causes beyond the control of JCI such as lightning, excessive voltage, mechanical shock, water damage, or damage arising out of abuse, alteration or improper application of the equipment.

The foregoing warranty shall apply only to the original buyer, and is and shall be in lieu of any and all other warranties, whether expressed or implied and of all other obligations or liabilities on the part of JCI. JCI neither assumes responsibility for, nor authorizes any other person purporting to act on its behalf to modify or to change this warranty, nor to assume for it any other warranty or liability concerning this product.

In no event shall JCI be liable for any direct, indirect or consequential damages, loss of anticipated profits, loss of time or any other losses incurred by the buyer in connection with the purchase, installation or operation or failure of this product.

Warning: JCI recommends that the entire system be completely tested on a regular basis. However, despite frequent testing, and due to, but not limited to, criminal tampering or electrical disruption, it is possible for this product to fail to perform as expected.

Important Information: Changes or modifications not expressly approved by JCI could void the user’s authority to operate this equipment.

EULA

IMPORTANT READ CAREFULLY: DSC Software purchased with or without Products and Components is copyrighted and is purchased under the following license terms:

This End User License Agreement ("EULA") is a legal agreement between You (the company, individual or entity who acquired the Software and any related Hardware) and Digital Security Controls, a division of Tyco Safety Products Canada Ltd. ("DSC"), the manufacturer of the integrated security systems and the developer of the software and any related products or components ("HARDWARE") which You acquired.

If the DSC software product ("SOFTWARE PRODUCT" or "SOFTWARE") is intended to be accompanied by HARDWARE, and is NOT accompanied by new HARDWARE, You may not use, copy or install the SOFTWARE PRODUCT. The SOFTWARE PRODUCT includes computer software, and may include associated media, printed materials, and "online" or electronic documentation.

Any software provided along with the SOFTWARE PRODUCT that is associated with a separate end user license agreement is licensed to You under the terms of that license agreement.

By installing, copying, downloading, storing, accessing or otherwise using the SOFTWARE PRODUCT, You agree unconditionally to be bound by the terms of this EULA, even if this EULA is deemed to be a modification of any previous arrangement or contract. If You do not agree to the terms of this EULA, DSC is unwilling to license the SOFTWARE PRODUCT to You, and You have no right to use it.

SOFTWARE PRODUCT LICENSE

The SOFTWARE PRODUCT is protected by copyright laws and international copyright treaties, as well as other intellectual property laws and treaties. The SOFTWARE PRODUCT is licensed, not sold.

1. GRANT OF LICENSE. This EULA grants You the following rights:

(a) Software Installation and Use - For each license You acquire, You may have only one copy of the SOFTWARE PRODUCT installed.

(b) Storage/Network Use - The SOFTWARE PRODUCT may not be installed, accessed, displayed, run, shared or used concurrently on or from different computers, including a workstation, terminal or other digital electronic device ("Device"). In other words, if You have several workstations, You will have to acquire a license for each workstation where the SOFTWARE will be used.

(c) Backup Copy - You may make back up copies of the SOFTWARE PRODUCT, but You may only have one copy per license installed at any given time. You may use the back up copy solely for archival purposes. Except as expressly provided in this EULA, You may not otherwise make copies of the SOFTWARE PRODUCT, including the printed materials accompanying the SOFTWARE.

2. DESCRIPTION OF OTHER RIGHTS AND LIMITATIONS

(a) Limitations on Reverse Engineering, Decompilation and Disassembly - You may not reverse engineer, decompile, or disassemble the SOFTWARE PRODUCT, except and only to the extent that such activity is expressly permitted by applicable law notwithstanding this limitation. You may not make any changes or modifications to the Software, without the written permission of an officer of DSC. You may not remove any proprietary notices, marks or labels from the Software Product. You shall institute reasonable measures to ensure compliance with the terms and conditions of this EULA.

(b) Separation of Components - The SOFTWARE PRODUCT is licensed as a single product. Its component parts may not be separated for use on more than one HARDWARE unit.

(c) Single INTEGRATED PRODUCT - If You acquired this SOFTWARE with HARDWARE, then the SOFTWARE PRODUCT is licensed with the HARDWARE as a single integrated product. In this case, the SOFTWARE PRODUCT may only be used with the HARDWARE as set forth in this EULA.

(d) Rental - You may not rent, lease or lend the SOFTWARE PRODUCT. You may not make it available to others or post it on a server or web site.

(e) Software Product Transfer - You may transfer all of Your rights under this EULA only as part of a permanent sale or transfer of the HARDWARE, provided You retain no copies, You transfer all of the SOFTWARE PRODUCT (including all component parts, the media and printed materials, any upgrades and this EULA), and provided the recipient agrees to the terms of this EULA. If the SOFTWARE PRODUCT is an upgrade, any transfer must also include all prior versions of the SOFTWARE PRODUCT.

(f) Termination - Without prejudice to any other rights, DSC may terminate this EULA if You fail to comply with the terms and conditions of this EULA. In such event, You must destroy all copies of the SOFTWARE PRODUCT and all of its component parts.

(g) Trademarks - This EULA does not grant You any rights in connection with any trademarks or service marks of DSC or its suppliers.

3. COPYRIGHT

All title and intellectual property rights in and to the SOFTWARE PRODUCT (including but not limited to any images, photographs, and text incorporated into the SOFTWARE PRODUCT), the accompanying printed materials, and any copies of the SOFTWARE PRODUCT, are owned by DSC or its suppliers. You may not copy the printed materials accompanying the SOFTWARE PRODUCT. All title and intellectual property rights in and to the content which may be accessed through use of the SOFTWARE PRODUCT are the property of the respective content owner and may be protected by applicable copyright or other intellectual property laws and treaties. This EULA grants You no rights to use such content. All rights not expressly granted under this EULA are reserved by DSC and its suppliers.

4. EXPORT RESTRICTIONS

You agree that You will not export or re export the SOFTWARE PRODUCT to any country, person, or entity subject to Canadian export restrictions.

5. CHOICE OF LAW: This Software License Agreement is governed by the laws of the Province of Ontario, Canada.

6. ARBITRATION

All disputes arising in connection with this Agreement shall be determined by final and binding arbitration in accordance with the Arbitration Act, and the parties agree to be bound by the arbitrator's decision. The place of arbitration shall be Toronto, Canada, and the language of the arbitration shall be English.

7. LIMITED WARRANTY

(a) NO WARRANTY

DSC PROVIDES THE SOFTWARE "AS IS" WITHOUT WARRANTY. DSC DOES NOT WARRANT THAT THE SOFTWARE WILL MEET YOUR REQUIREMENTS OR THAT OPERATION OF THE SOFTWARE WILL BE UNINTERRUPTED OR ERROR-FREE.

(b) CHANGES IN OPERATING ENVIRONMENT

DSC shall not be responsible for problems caused by changes in the operating characteristics of the HARDWARE, or for problems in the interaction of the SOFTWARE PRODUCT with non-DSC-SOFTWARE or HARDWARE PRODUCTS.

(c) LIMITATION OF LIABILITY; WARRANTY REFLECTS ALLOCATION OF RISK

IN ANY EVENT, IF ANY STATUTE IMPLIES WARRANTIES OR CONDITIONS NOT STATED IN THIS LICENSE AGREEMENT, DSC'S ENTIRE LIABILITY UNDER ANY PROVISION OF THIS LICENSE AGREEMENT SHALL BE LIMITED TO THE GREATER OF THE AMOUNT ACTUALLY PAID BY YOU TO LICENSE THE SOFTWARE PRODUCT AND FIVE CANADIAN DOLLARS (CAD\$5.00). BECAUSE SOME JURISDICTIONS DO NOT ALLOW THE EXCLUSION OR LIMITATION OF LIABILITY FOR CONSEQUENTIAL OR INCIDENTAL DAMAGES, THE ABOVE LIMITATION MAY NOT APPLY TO YOU.

(d) DISCLAIMER OF WARRANTIES

THIS WARRANTY CONTAINS THE ENTIRE WARRANTY AND SHALL BE IN LIEU OF ANY AND ALL OTHER WARRANTIES, WHETHER EXPRESSED OR IMPLIED (INCLUDING ALL IMPLIED WARRANTIES OF MERCHANTABILITY OR FITNESS FOR A PARTICULAR PURPOSE) AND OF ALL OTHER OBLIGATIONS OR LIABILITIES ON THE PART OF DSC. DSC MAKES NO OTHER WARRANTIES. DSC NEITHER ASSUMES NOR AUTHORIZES ANY OTHER PERSON PURPORTING TO ACT

ON ITS BEHALF TO MODIFY OR TO CHANGE THIS WARRANTY, NOR TO ASSUME FOR IT ANY OTHER WARRANTY OR LIABILITY CONCERNING THIS SOFTWARE PRODUCT.

(e) EXCLUSIVE REMEDY AND LIMITATION OF WARRANTY

UNDER NO CIRCUMSTANCES SHALL DSC BE LIABLE FOR ANY SPECIAL, INCIDENTAL, CONSEQUENTIAL OR INDIRECT DAMAGES BASED UPON BREACH OF WARRANTY, BREACH OF CONTRACT, NEGLIGENCE, STRICT LIABILITY, OR ANY OTHER LEGAL THEORY. SUCH DAMAGES INCLUDE, BUT ARE NOT LIMITED TO, LOSS OF PROFITS, LOSS OF THE SOFTWARE PRODUCT OR ANY ASSOCIATED EQUIPMENT, COST OF CAPITAL, COST OF SUBSTITUTE OR REPLACEMENT EQUIPMENT, FACILITIES OR SERVICES, DOWN TIME, PURCHASERS TIME, THE CLAIMS OF THIRD PARTIES, INCLUDING CUSTOMERS, AND INJURY TO PROPERTY.

WARNING: DSC recommends that the entire system be completely tested on a regular basis. However, despite frequent testing, and due to, but not limited to, criminal tampering or electrical disruption, it is possible for this SOFTWARE PRODUCT to fail to perform as expected.

Website: www.dsc.com

Tech. support: 1-800- 387-3630