

SPACER ORIENTATION

INSTALLATION NOTES

1. Cut out template and place it around unit as shown.
2. Remove backing paper from gasket, install gasket around template with surface "A" lying directly above the template, discard template.
3. Using spacer as drill template mark and drill three (3) 3/16 in. diameter holes. Complete installation as shown.
OPTIONAL: If anchors are not required, use spacer as template, mark and drill (3) holes using a #32 drill bit.

CLEANING INSTRUCTIONS

Rinse with water to remove abrasive dust and dirt. Wash with soap or mild detergent using a soft cloth. **DO NOT SCRUB OR USE BRUSHES OR ABRASIVES.** Rinse once more, then dry with a soft cloth or chamois. To remove grease or wet paint, rub gently with a damp cloth thoroughly with naphtha. Then wash and rinse. **DO NOT USE RAZOR BLADES.**

⚠ WARNING: This product can expose you to chemicals including Dichloromethane, which is known to the State of California to cause cancer, and Bisphenol A (BPA), which is known to the State of California to cause birth defects or other reproductive harm. For more information go to www.P65Warnings.ca.gov.

Three year warranty or a one year limited warranty (from date of purchase) on most products. See website for details. Electronic warranty form at www.sti-usa.com/wc14.

INSTALLATION OF STI-6514 PROTECTIVE COVER

All specifications and information shown were current as of publication and are subject to change without notice.

BIO6514 AUG2008



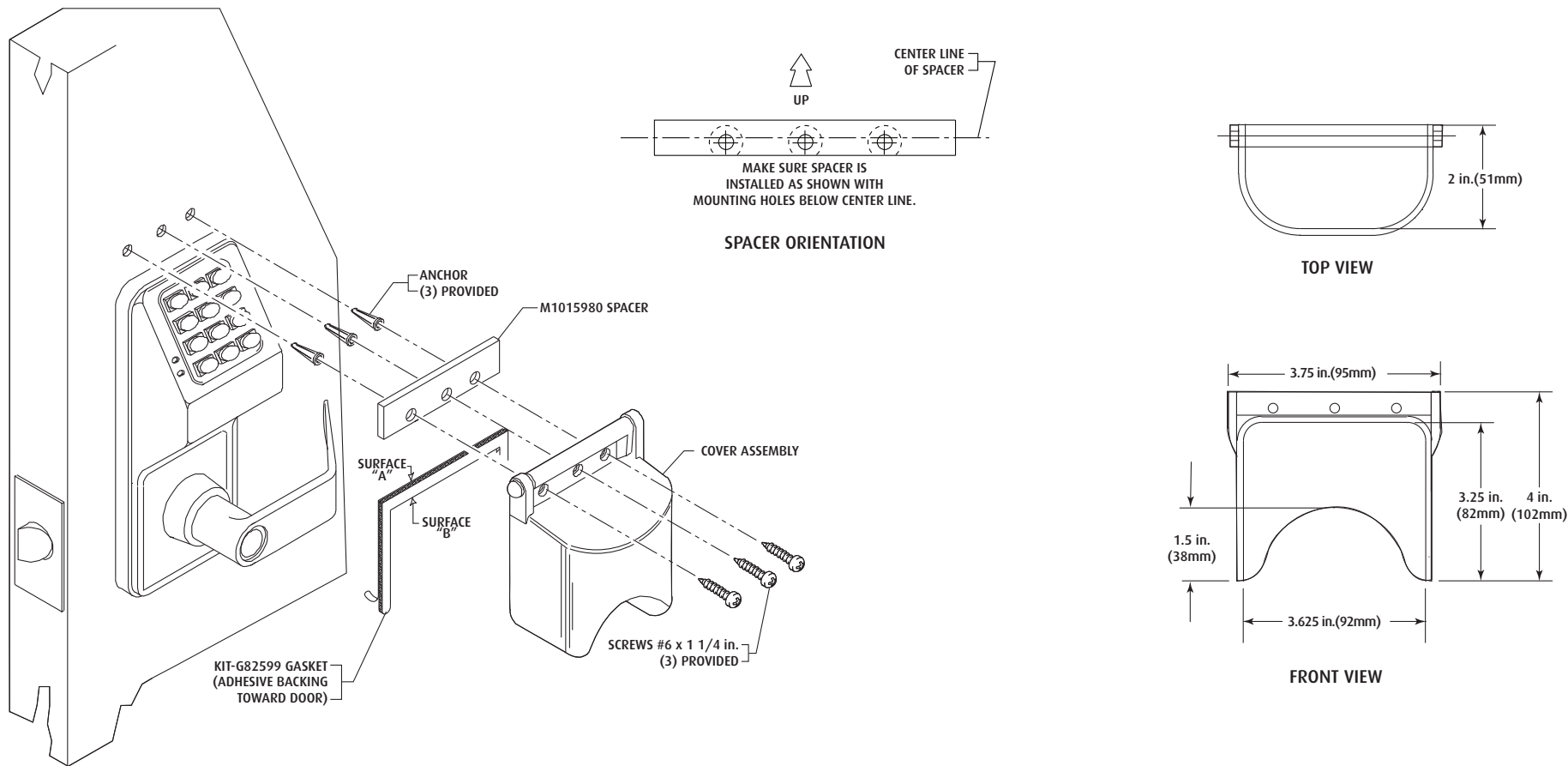

INSTALLATION NOTES

1. Remove backing paper and center gasket (G82599) left to right around lock with surface "B" against top of lock.
2. Next center spacer M1015980 with bottom of spacer lying on surface "A" of gasket.
3. Using spacer as template, mark and drill three (3) 3/16 in. DIA. holes. Complete assembly as shown.
Optional: if anchors are not required use spacer as template, mark and drill (3) holes using a # 36 drill size.

CLEANING INSTRUCTIONS

Rinse cover with water to remove abrasive dust and dirt. Wash with soap or mild detergent using a soft cloth. (DO NOT SCRUB.) Rinse once more, then dry with a soft cloth or chamois. To remove grease or wet paint, rub gently with a cloth wetted thoroughly with naphtha, then wash and rinse. (DO NOT USE RAZOR BLADES.)

WARNING: This product can expose you to chemicals including Dichloromethane, which is known to the State of California to cause cancer, and Bisphenol A (BPA), which is known to the State of California to cause birth defects or other reproductive harm. For more information go to www.P65Warnings.ca.gov.

Three year warranty or a one year limited warranty (from date of purchase) on most products. See website for details. Electronic warranty form at www.sti-usa.com/wc14.

INSTALLATION OF STI-6516 MINI BOPPER STOPPER®

All specifications and information shown were current as of publication and are subject to change without notice.

6516IS MAY2006



**ADA
Compliant**